

Montageanweisung / Installation instructions / Instruction de montage / Istruzioni di montaggio
Montagehandleiding / Instrukcja montażu / Montaj talimatları / Инструкция по монтажу

CUBE

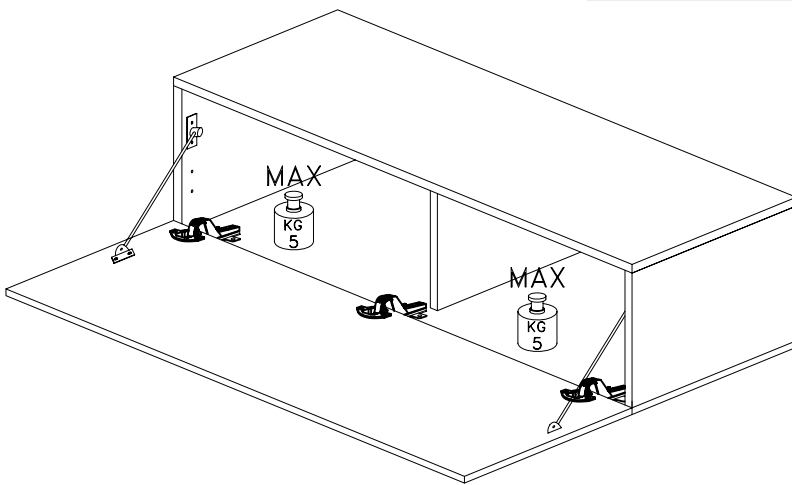
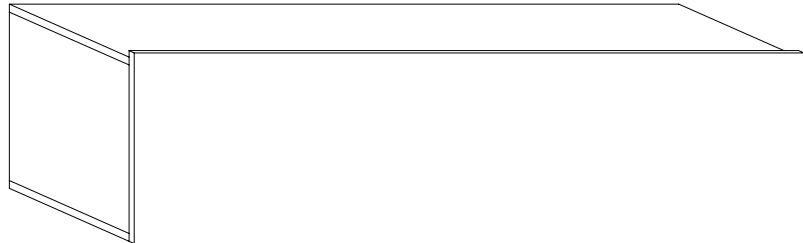
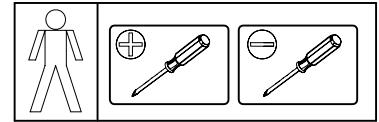

D Bitte lesen Sie diese Montageanleitung gut durch, da wir für Fehler, die durch falsche Montage entstehen, Keine Haftung übernehmen!

GB Please read these installation instructions through carefully as we cannot accept any liability for faults occurring as a result of incorrect installation!

F Veuillez lire attentivement cette notice de montage, car nous déclinons toute responsabilité en cas d'erreurs découlant d'un montage erroné!

I Prego leggere attentamente le istruzioni per il montaggio, poiché decliniamo qualsiasi responsabilità per difetti derivanti da un montaggio errato.

NL Leest u alstubleef deze montagehandleiding goed door, voor fouten door verkeerde montage zijn wij niet verantwoordelijk.

PL Proszę uważnie zapoznać się z instrukcją montażu, ponieważ nie ponosimy odpowiedzialności za niewłaściwy montaż.

TR İlk önce kullanma klavuzunu iyi okuyun, yalnız montaj yaparsanız bunun sorumlusu biz değildir.

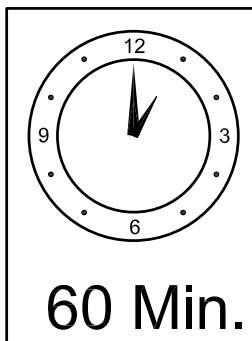

Total Kollis 1 Stuecke
Total colli 1 pieces
Numero total des colis: 1
Colli totali 1
Totaal 1 colli's
Razem sztuk 1
Toplam parçalar 1
количество Всего 1

S E R V I C E K A R T E

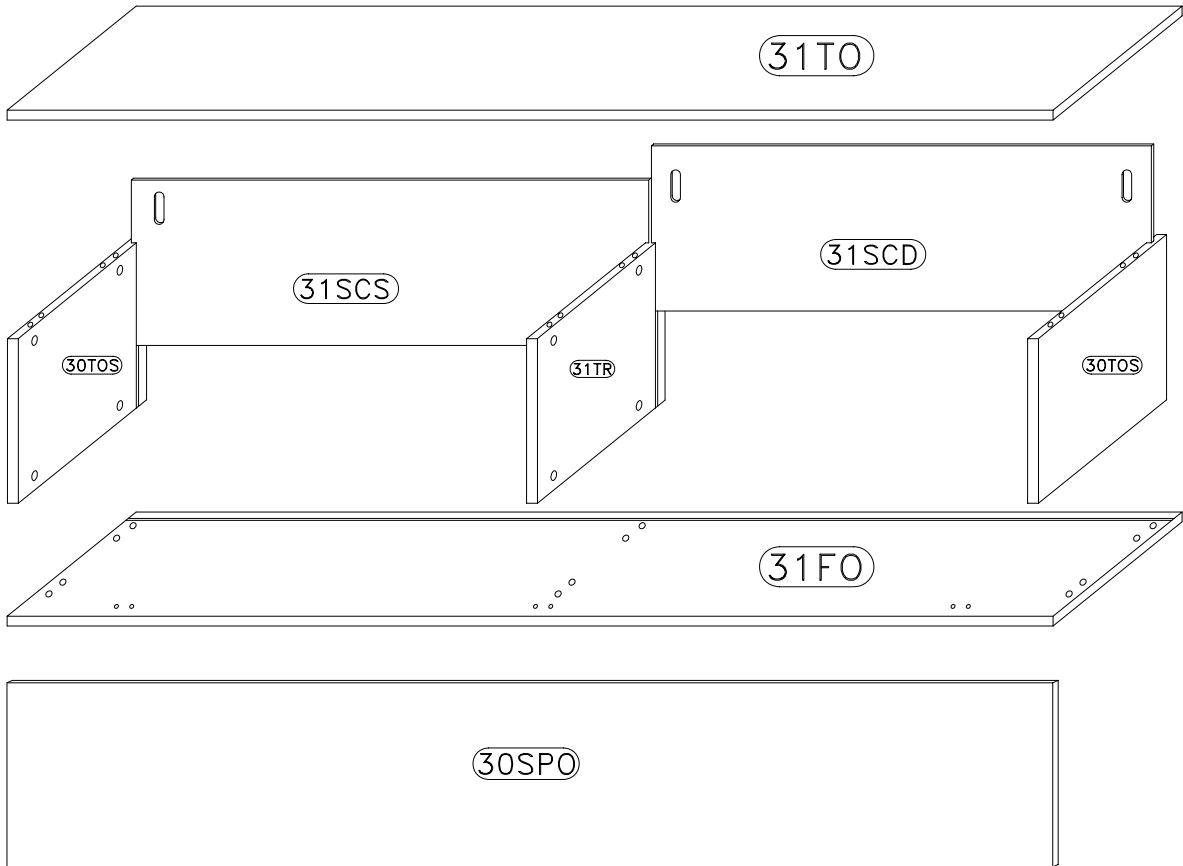
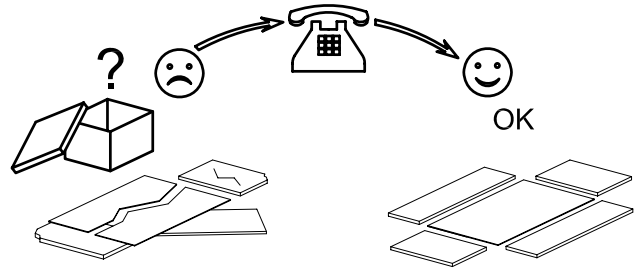
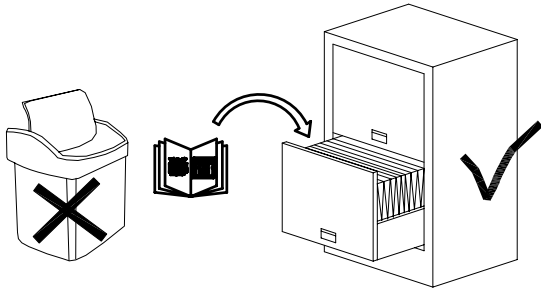

ONDERDELEN LYST-SERVICEKARTE-FORMULAIRE DEMANDES SAV-SPAREPARTS LIST-SCHEDA DI SERVIZIO

BESLAG-BESCHLAEGE - QUINCALLERIE - HARDWARE - FERRAMENTA

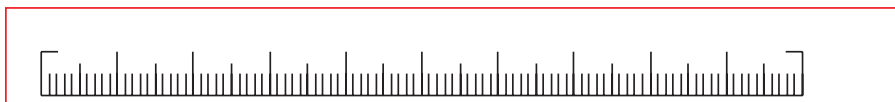
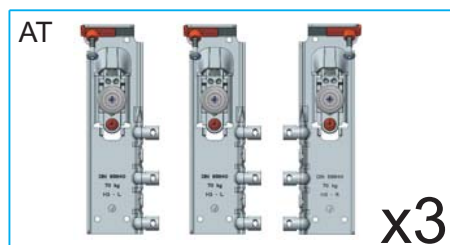
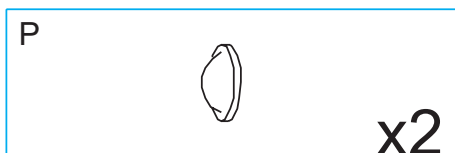
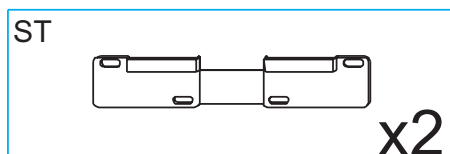
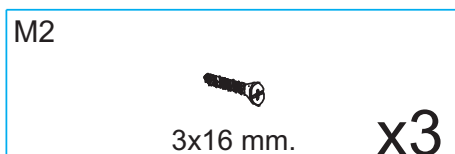
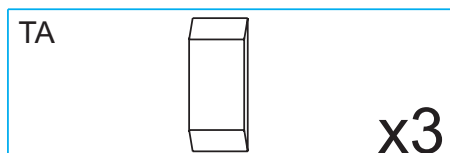
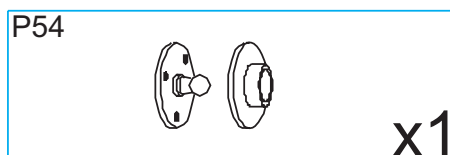
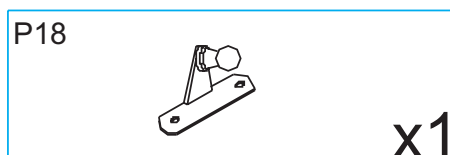
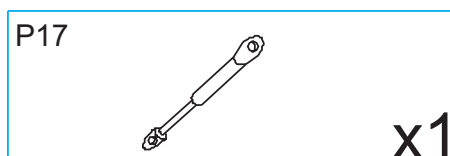
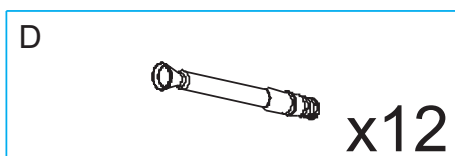
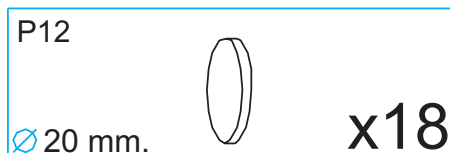
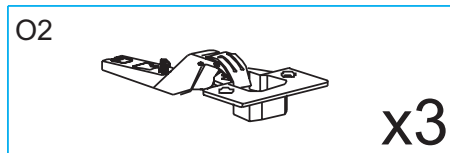
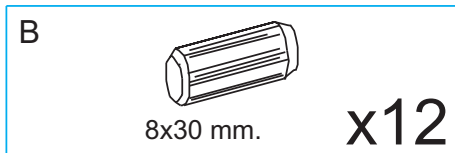
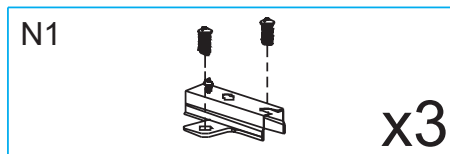
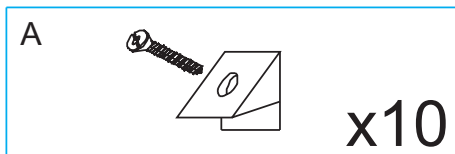

1

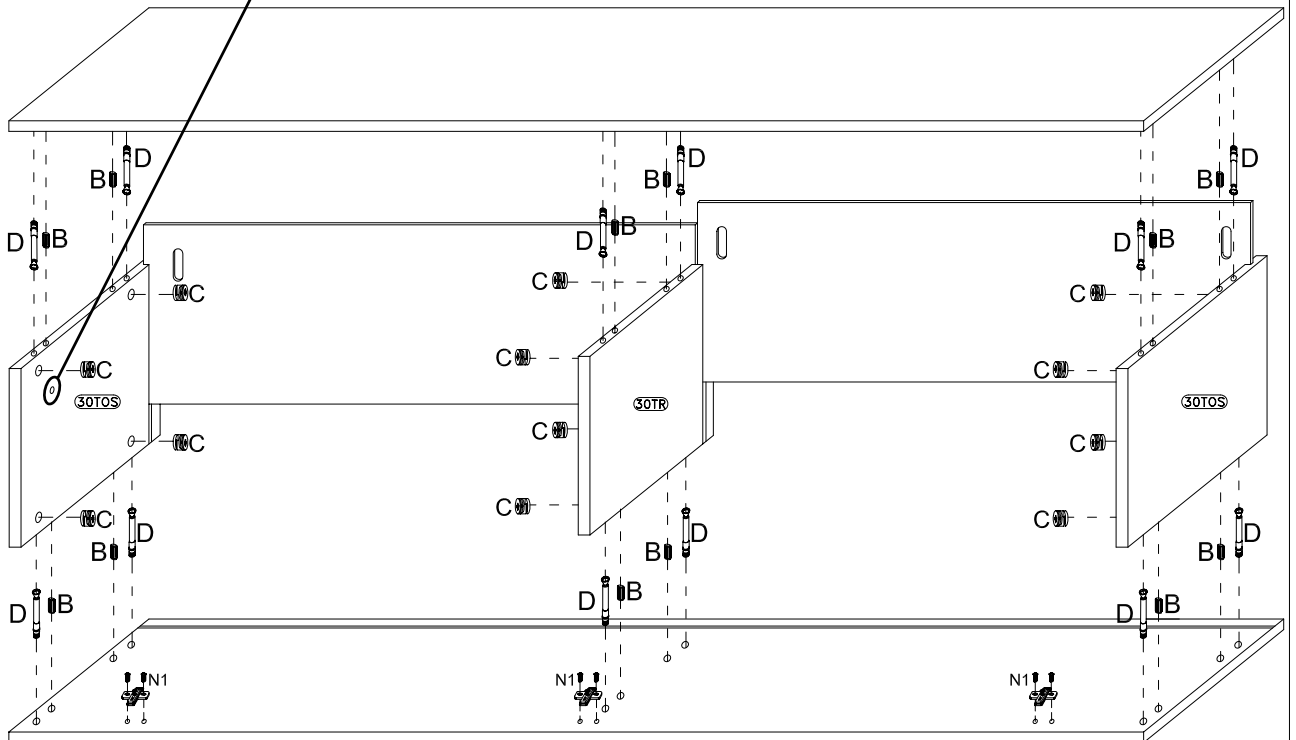
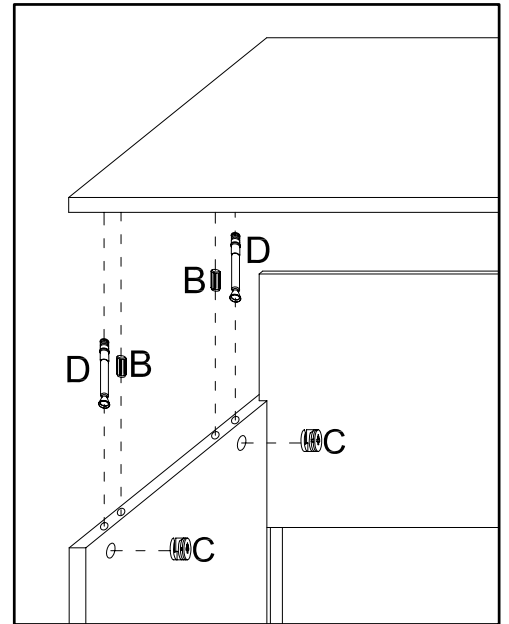
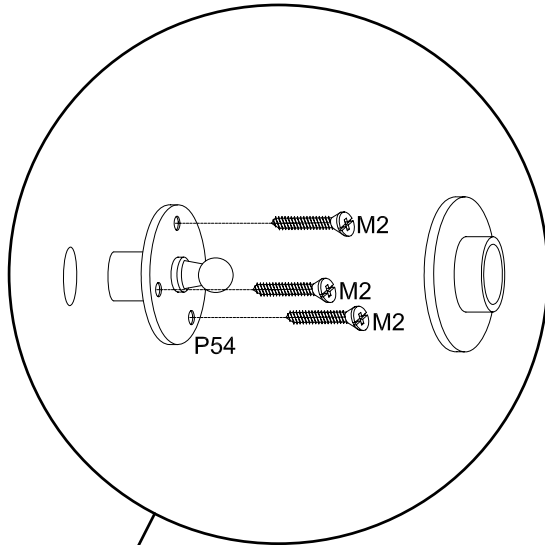
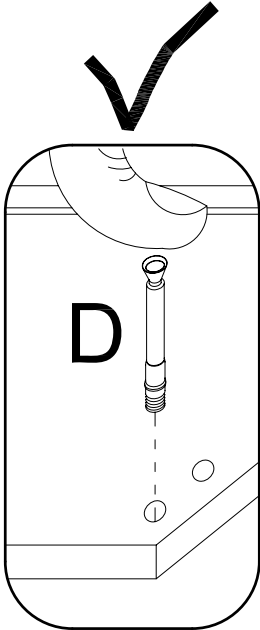
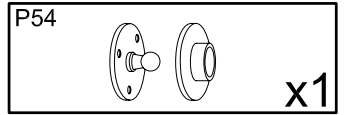
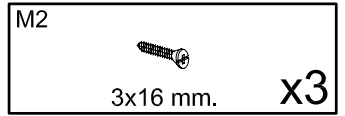
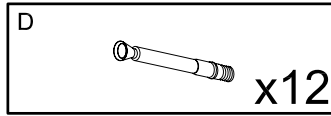
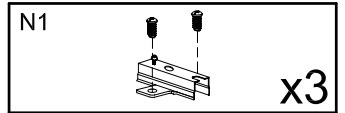
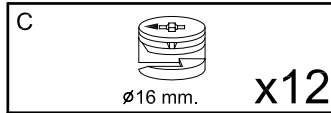
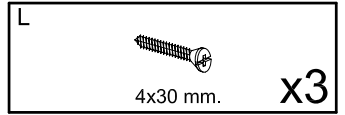
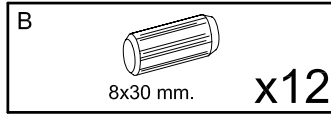
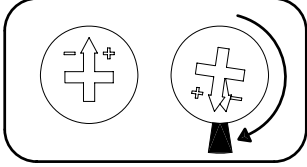
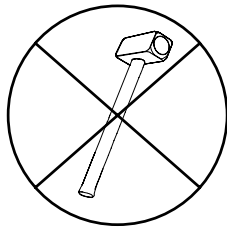
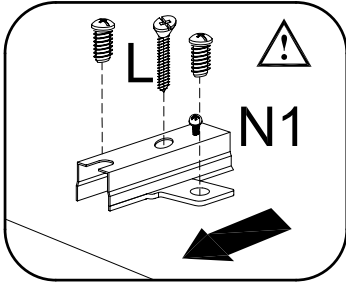

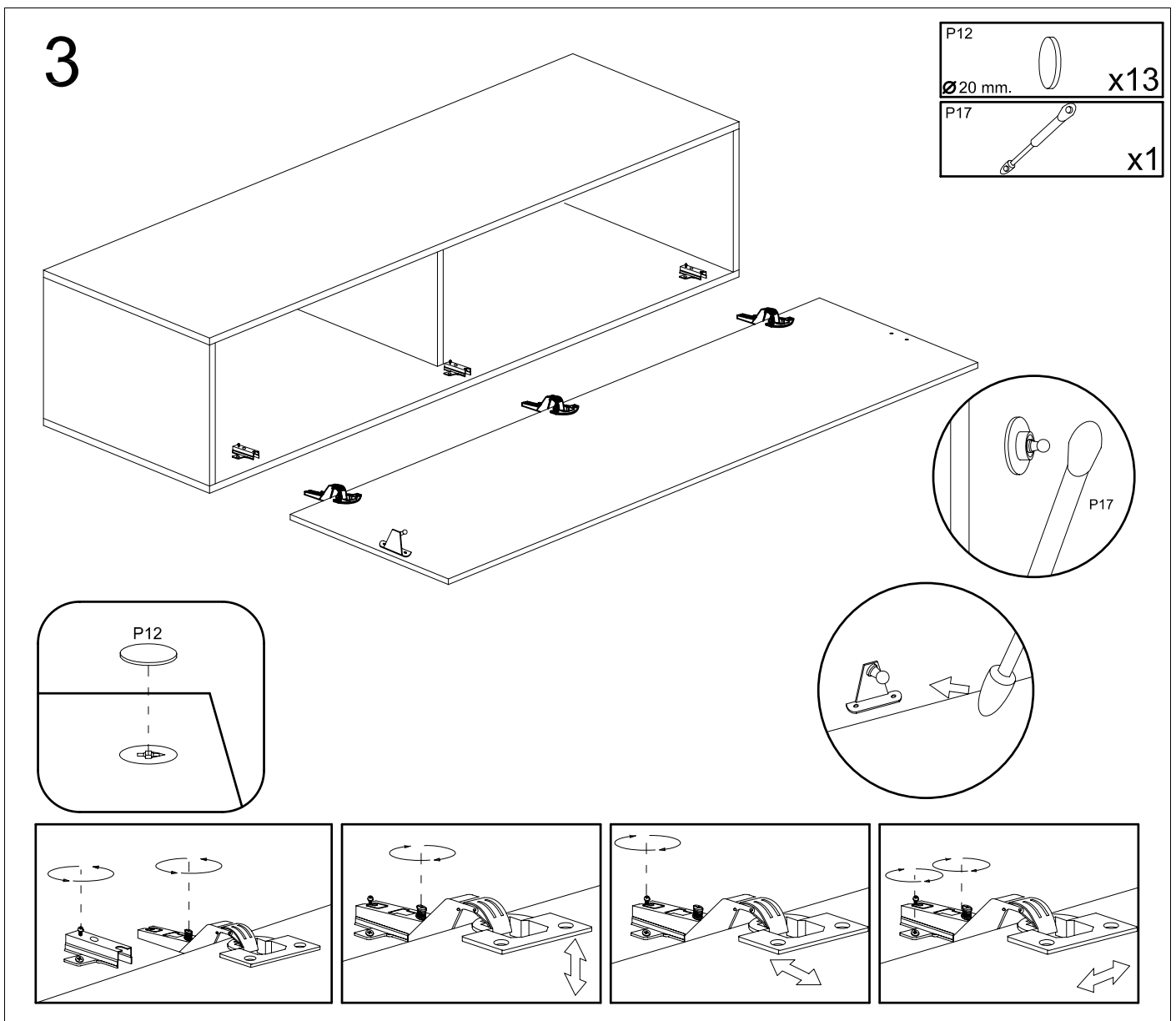
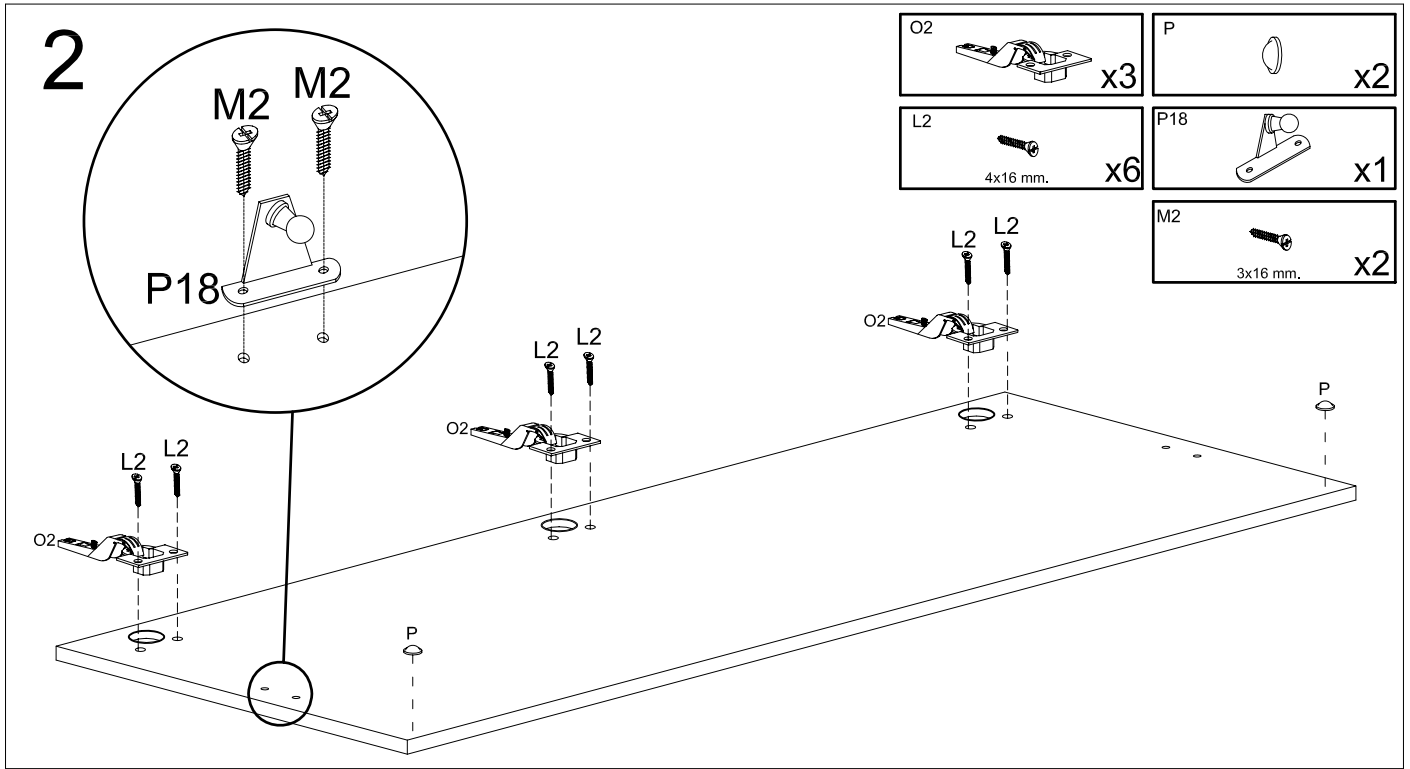

5

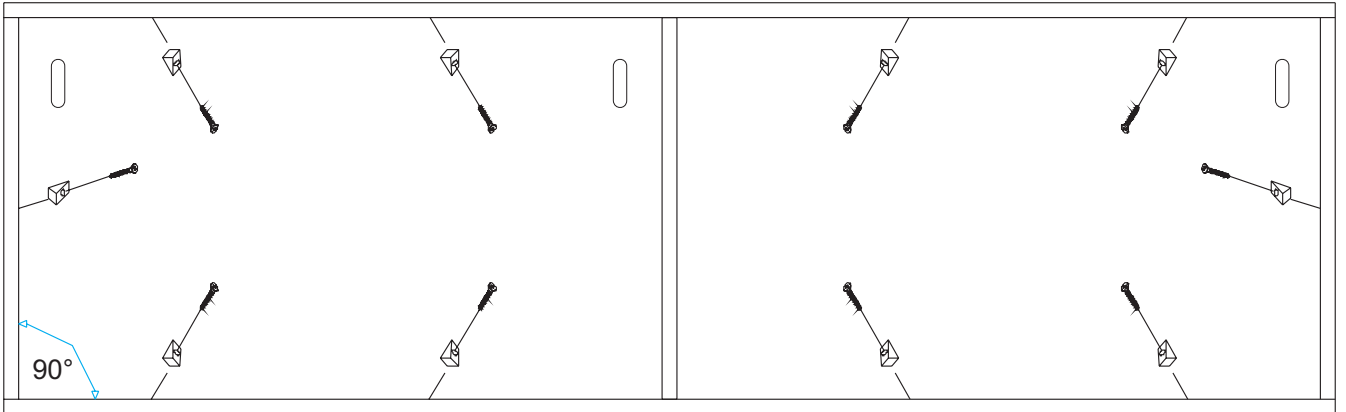
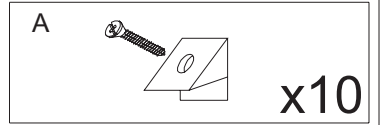
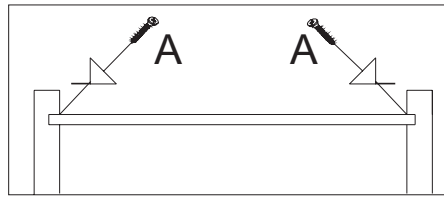

4

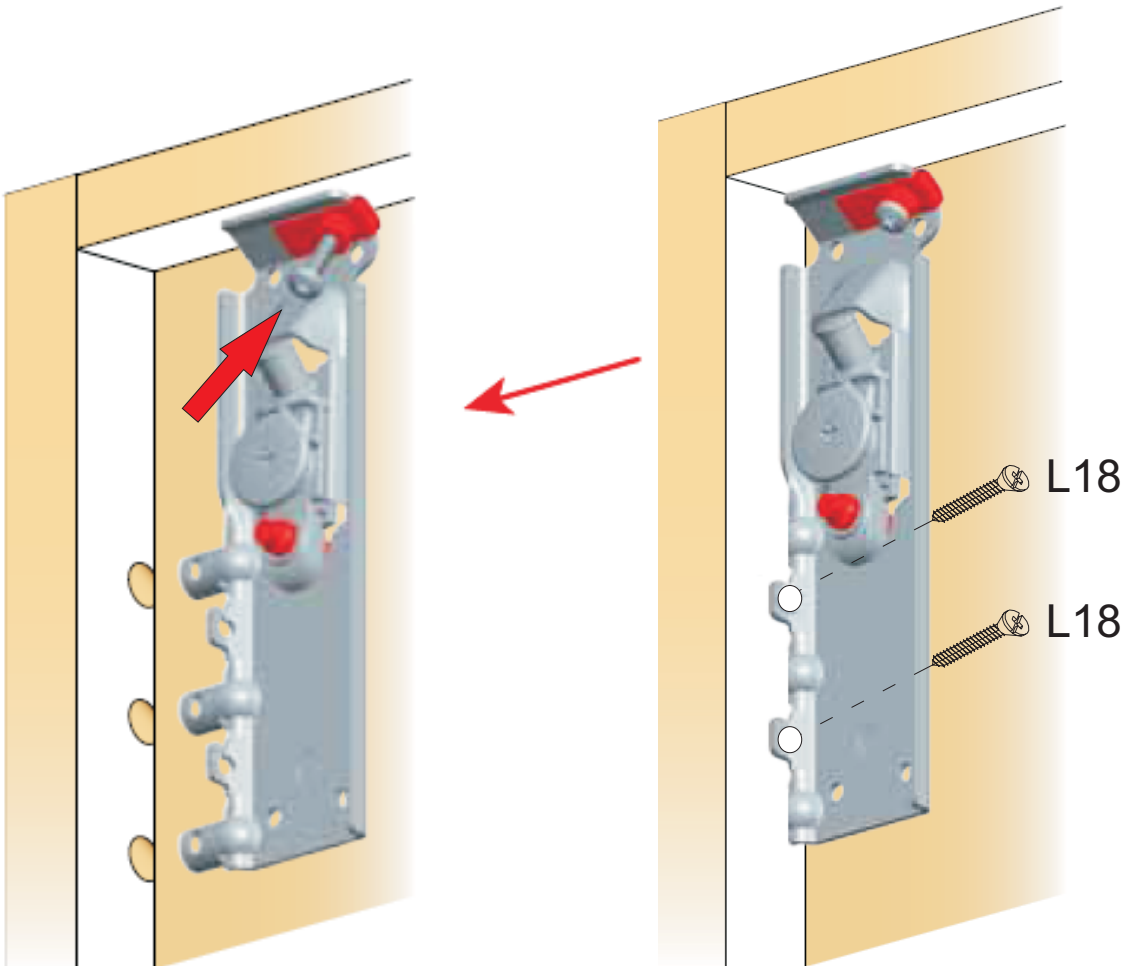
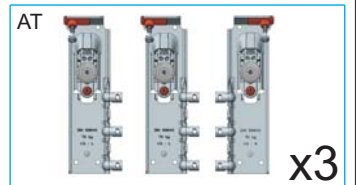
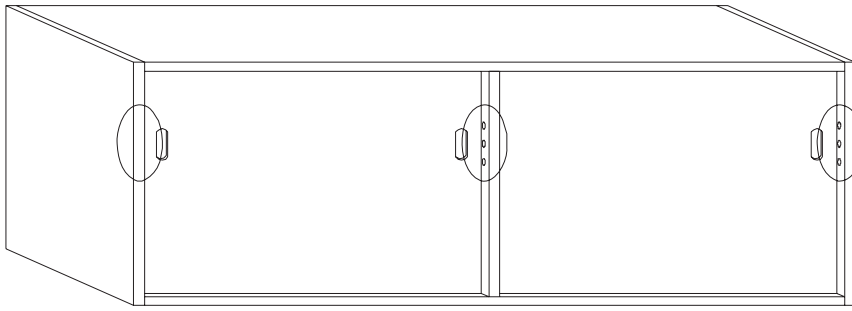

6

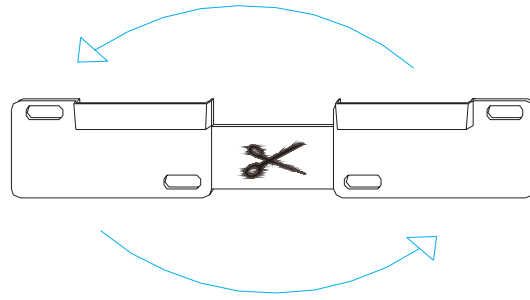

ST

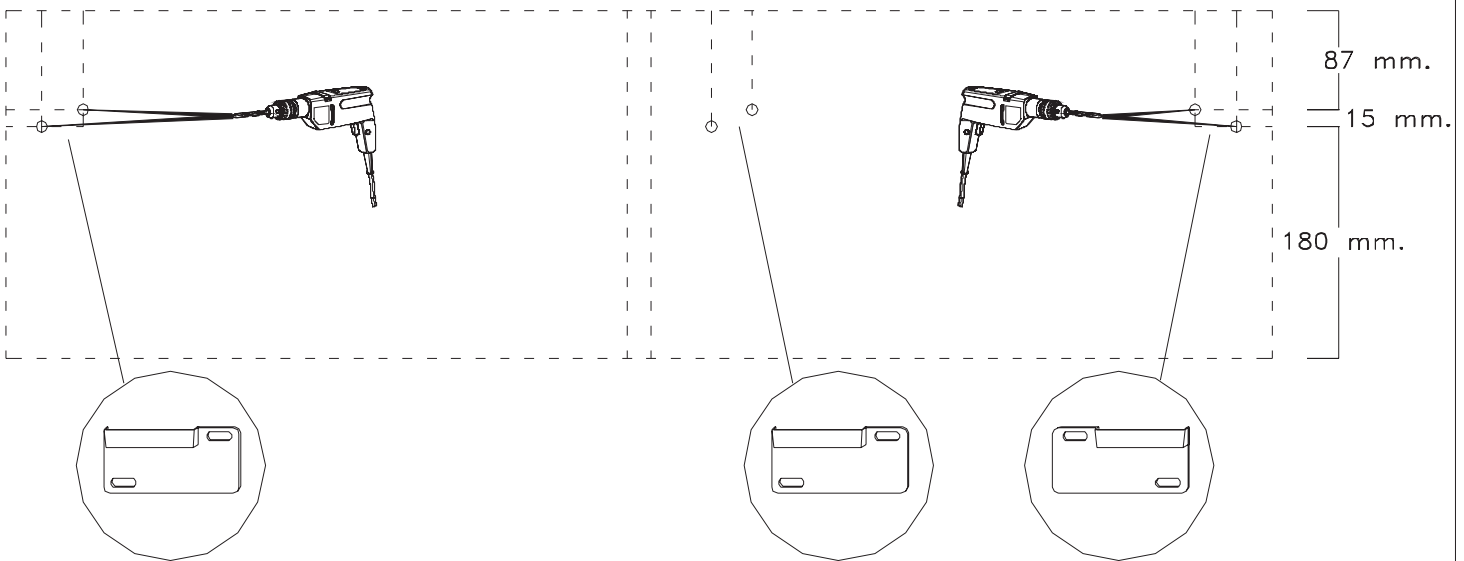
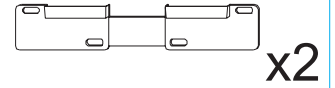

Sehr geehrter Kunde, die Montage der Haengeelemente muss von Fachpersonal ausgefuehrt werden!
Bitte verwenden Sie eigene, der Beschaffenheit der Wand entsprechende Duebel. Zu Ihrer eigenen
Sicherheit legen wir dem Beschlagbeutel keine Fischerduebel bei.

Gentile Cliente

Il montaggio dei pensili deve essere effettuato da personale competente.

I tasselli di fissaggio non sono compresi nella ferramenta.

Scegliere il tipo di tassello per il fissaggio più adatto alla tipologia di muro.

Assicurarsi l'idoneità della parete per un sostegno sicuro del pensile.

Cher client,

l'installation des meubles suspendus doit être effectuée par un personnel compétent.

Les fischers ne sont pas inclus dans la quincaillerie.

Choisir les types des fischers pour le fixage apte au mur.

S'assurer de l'adéquation du mur pour support sûr du meuble

Dear Customer

The assembling of the hanging elements must be done by a competent staff.

The fishers are not included in the hardware package.

Choose the fisher more suitable to the type of the wall.

Ensure the suitability of the wall for a secure support of the hanging element.

7

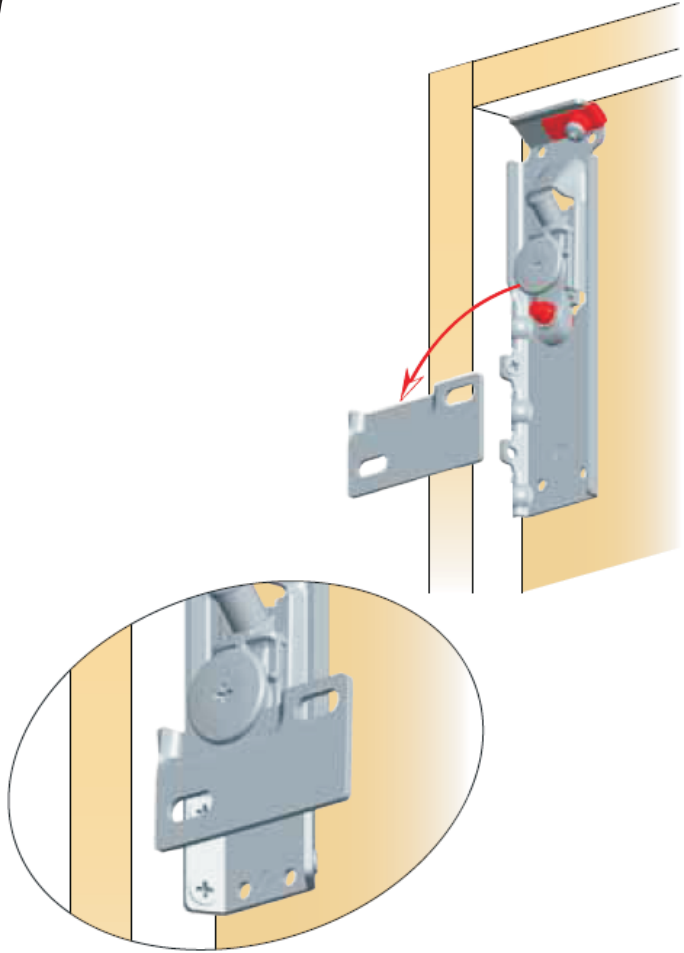

9

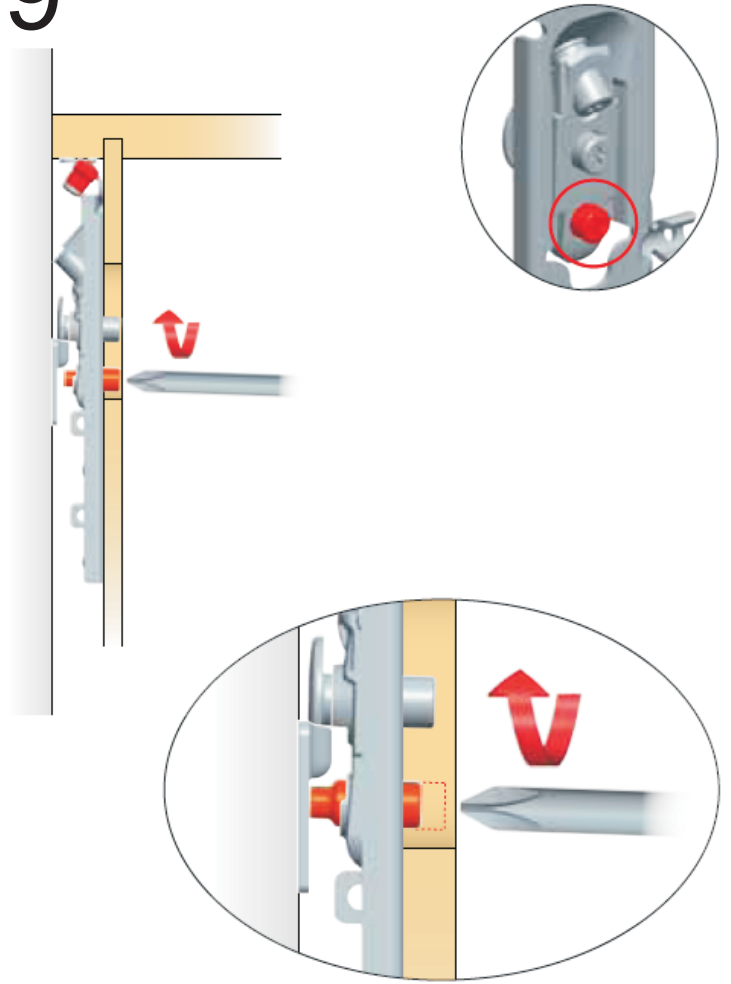

8

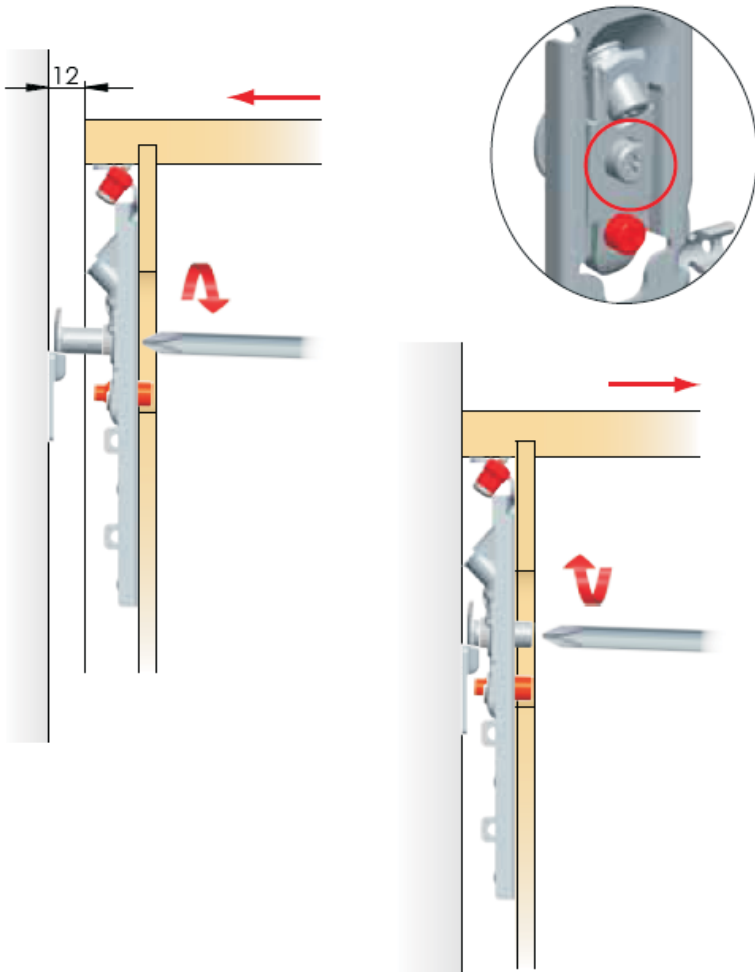

10

