

NOUS

LIVING

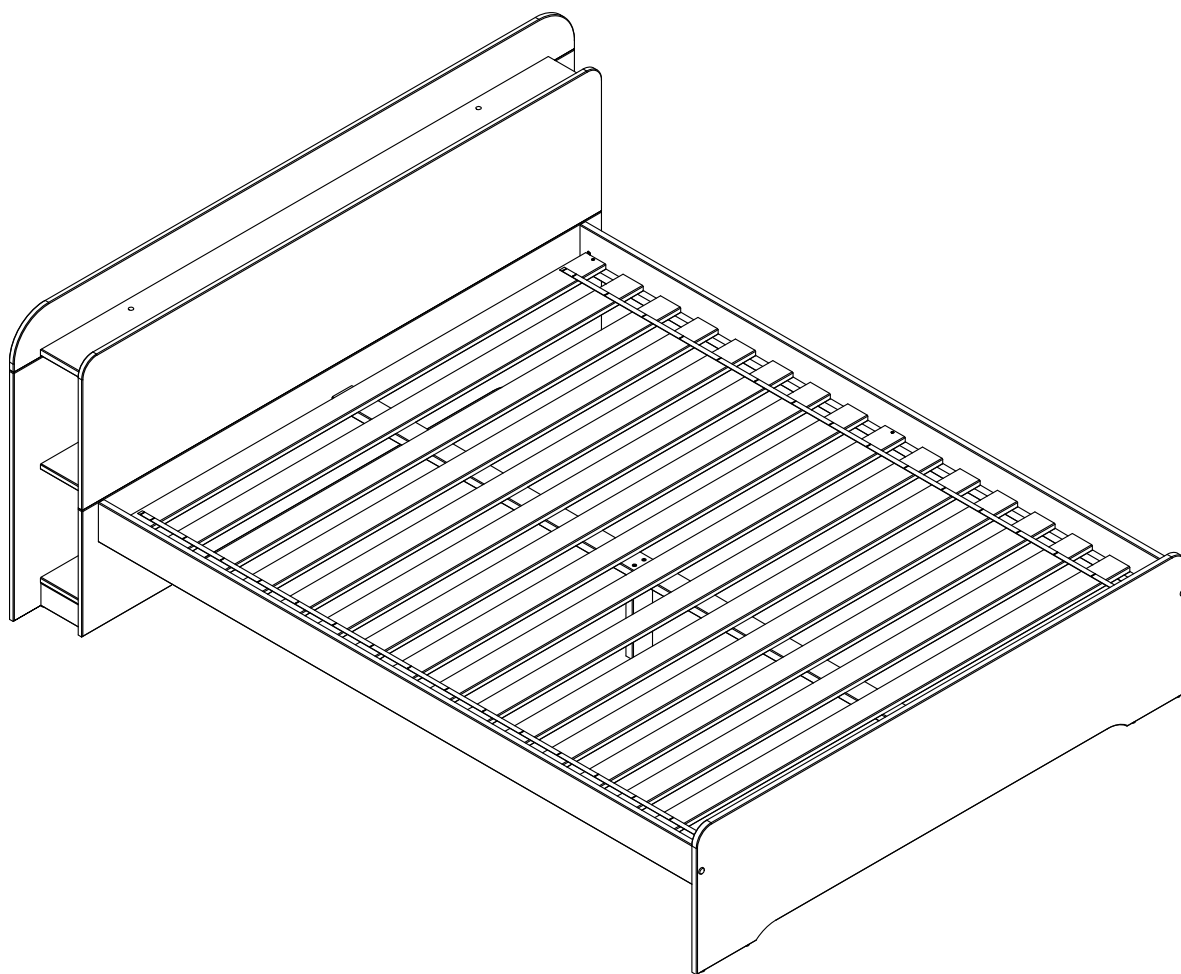

RUMBLE BED 160x200

montage tekening assembly drawing
montagezeichnung croquis montaj resmini

1. Bestudeer zorgvuldig de montagetekening voordat u met monteren begint.
 2. Neem de onderdelen en panelen voorzichtig uit de verpakking en leg ze op volgorde en controleer of alles compleet is.
 3. Leg het verpakkingsmateriaal ter bescherming onder het te monteren artikel.
 4. Volg met het monteren exact het stappenplan zoals in de tekening aangegeven.
 5. Begin met het monteren, wees voorzichtig, forceer niets.
 6. Bewaar deze montagetekening zorgvuldig. U heeft deze misschien nodig in het geval u onderdelen wilt aanvragen.
1. Study the assembly drawing carefully before starting the assembly.
 2. Carefully remove the parts and panels from the packing and place them in sequence. Check to see that nothing is missing.
 3. For extra protection, place the packing material under the item to be assembled.
 4. When assembling, follow the step-by-step instructions exactly as given on the drawing.
 5. Start the assembly. Be careful not to force anything.
 6. Take care to save the assembly drawing. It could be needed in case you need to order parts.
1. Studieren Sie die Montagezeichnung gut, bevor Sie mit der Montage beginnen.
 2. Nehmen Sie die Zubehörteile und Paneelen vorsichtig aus der Verpackung, legen Sie sie in die richtige Reihenfolge und kontrollieren Sie, ob alles komplett ist.
 3. Legen Sie das Verpackungsmaterial zum Schutz unter den zu montierenden Artikel.
 4. Folgen Sie bei der Montage genau dem Schritteplan, wie er in der Zeichnung angegeben ist.
 5. Beginnen Sie mit der Montage, seien Sie vorsichtig, übereilen Sie nichts.
 6. Bewahren Sie diese Montagezeichnung gut auf. Sie benötigen diese möglicherweise zur Bestellung von Zubehörteilen.
1. Examinez soigneusement le croquis avant de procéder au montage.
 2. Sortez soigneusement les pièces et les panneaux de leur emballage, placez-les dans l'ordre et assurez-vous que rien ne manque.
 3. Placez le matériel d'emballage protecteur sous l'article à monter.
 4. Suivez scrupuleusement les étapes de montage comme indiqué sur le croquis.
 5. Commencez le montage. Soyez prudent et ne forcez pas.
 6. Conservez soigneusement le croquis de montage. Vous en aurez peut-être besoin lorsque vous souhaiterez remplacer un élément.
1. Montaj i?ine ba?lamadan önce montaj resmini dikkatle inceleyiniz.
 2. Parçaları ve panoları ambalajından özenle çıkartınız, sıraya koyunuz ve her?eyin tam olup olmadığını kontrol ediniz.
 3. Monte edilecek nesnenin altına, koruma amacıyla ambalaj malzemesi seriniz.
 4. Montaj sırasında resimde belirtildi?i gibi safha planını takip ediniz.
 5. Montaja ba?layınız, dikkatli olunuz ve hiç bir parçayı zorlamayınız.
 6. Bu montaj resmini iyice saklayınız. ?eride parça ihtiyacı sırasında gerekli olabilir.
- (1) يجب النظر في رسم التركيب بدقة قبل الشروع في عملية التركيب.
 - (2) يجب أخذ الأقسام والألواح من العلبة بحذر ووضعها حسب ترتيب كما يجب التأكد من وجود جميع الأقسام.
 - (3) ضع مواد التغليف تحت السلعة المقرر تركيبها وذلك للحماية.
 - (4) يجب متابعة المراحل الموصوفة في رسم التركيب خطوة خطوة.
 - (5) أبدأ عملية التركيب, يجب القيام بذلك بحذر, لا تربط شيئاً بشدة حتى لا تخسر شيئاً.
 - (6) يجب حفظ هذا الرسم. إذا أردت طلب أقسام احتياطية قد تحتاجه.

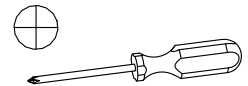
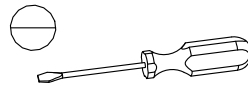
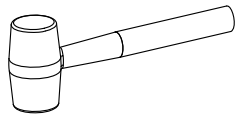
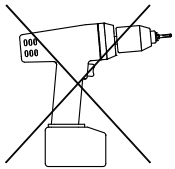
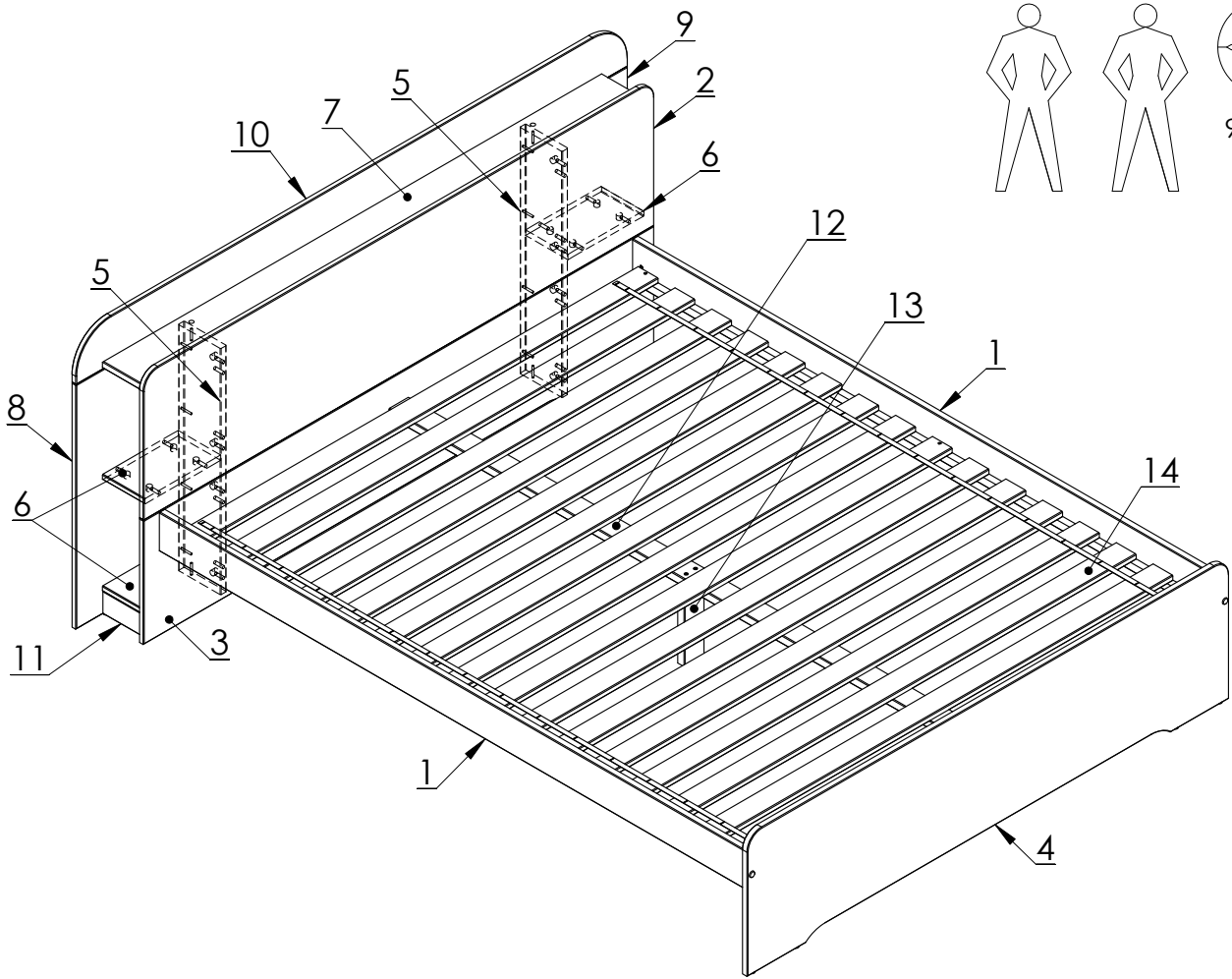

A		8x30	x8
B		8x40	x27
C		10x40	x2
D		M6x55	x4
E		M6x10x13	x4
F		7x50	x17
G		7x60	x2
H		7x34	x31
J		7x68	x4
K		15x12	x39

L		3,5x15	x4
M		3,5x40	x6
N		45x12	x2
P		D17x3	x12
R		M8x20xD28	x1
S		M8x20x10,4	x1
T		D4x13	x2
U		D15x18	x4
V		D20	x4
		4mm	x1

①

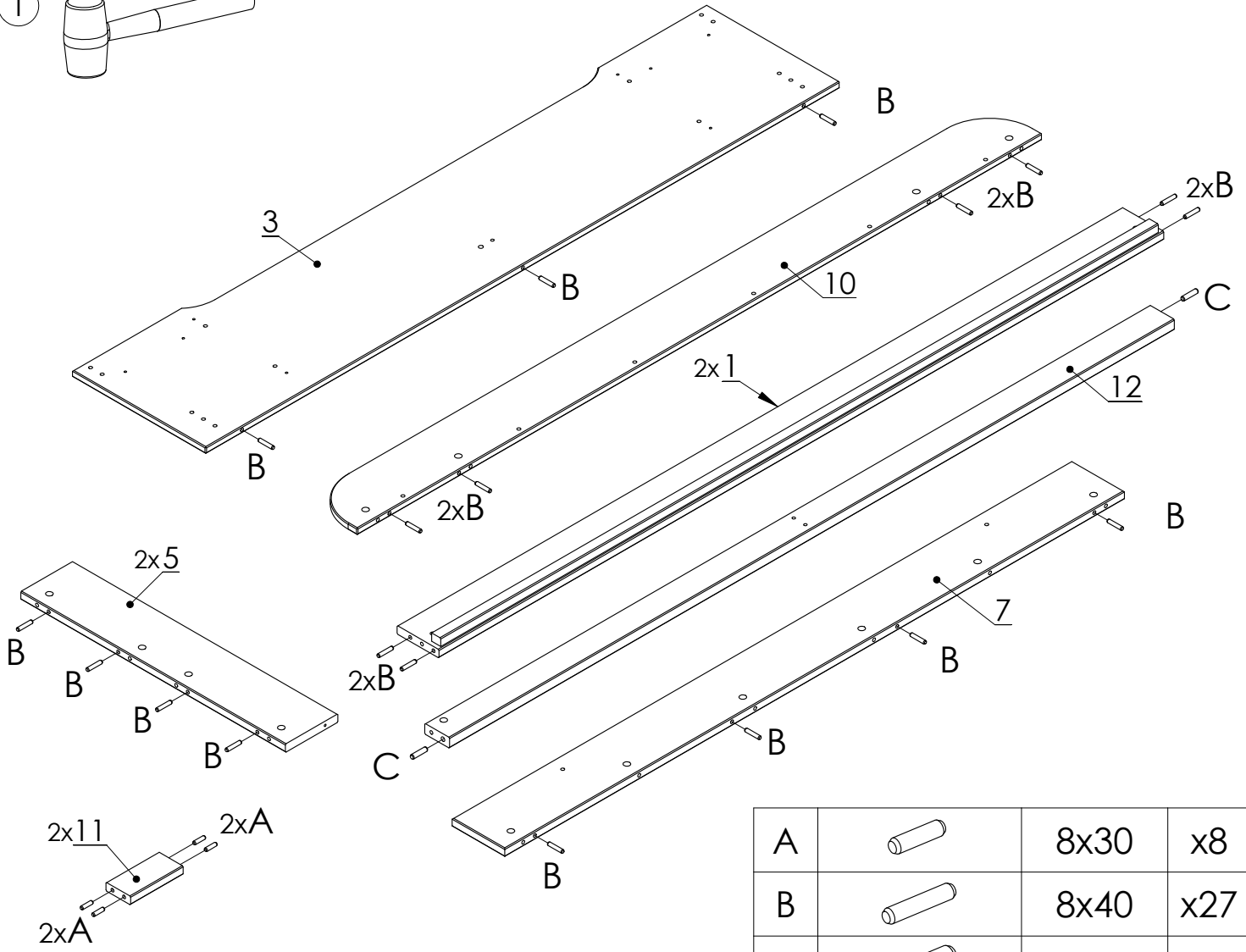
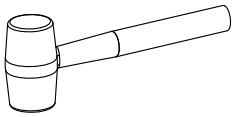

A		8x30	x8
B		8x40	x27
C		10x40	x2

②

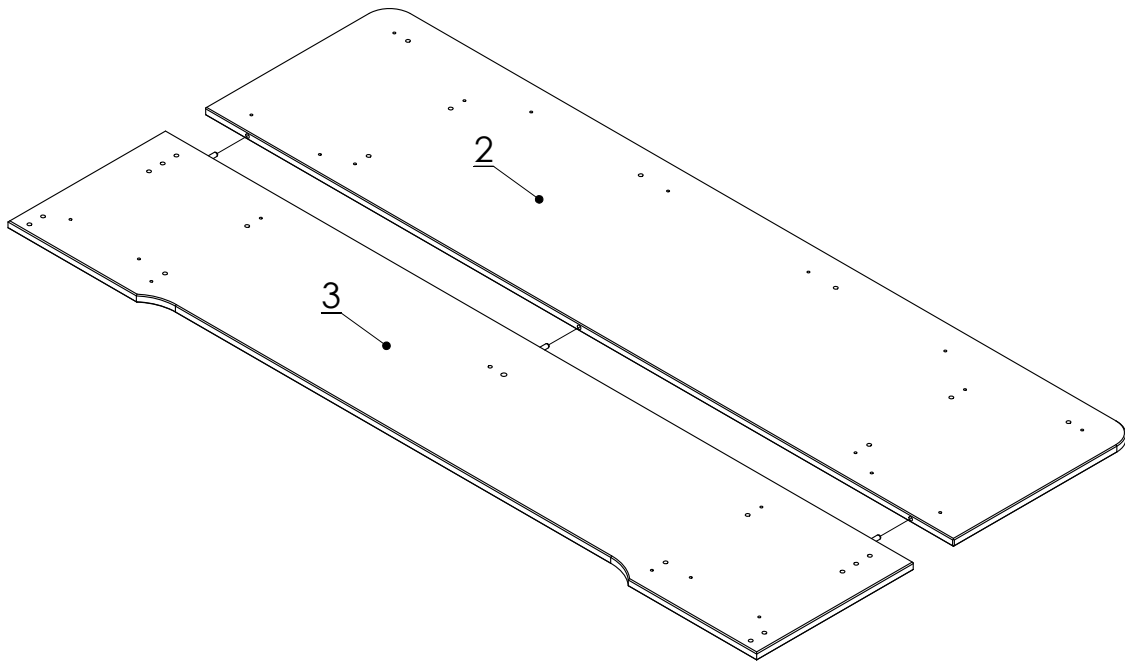

3

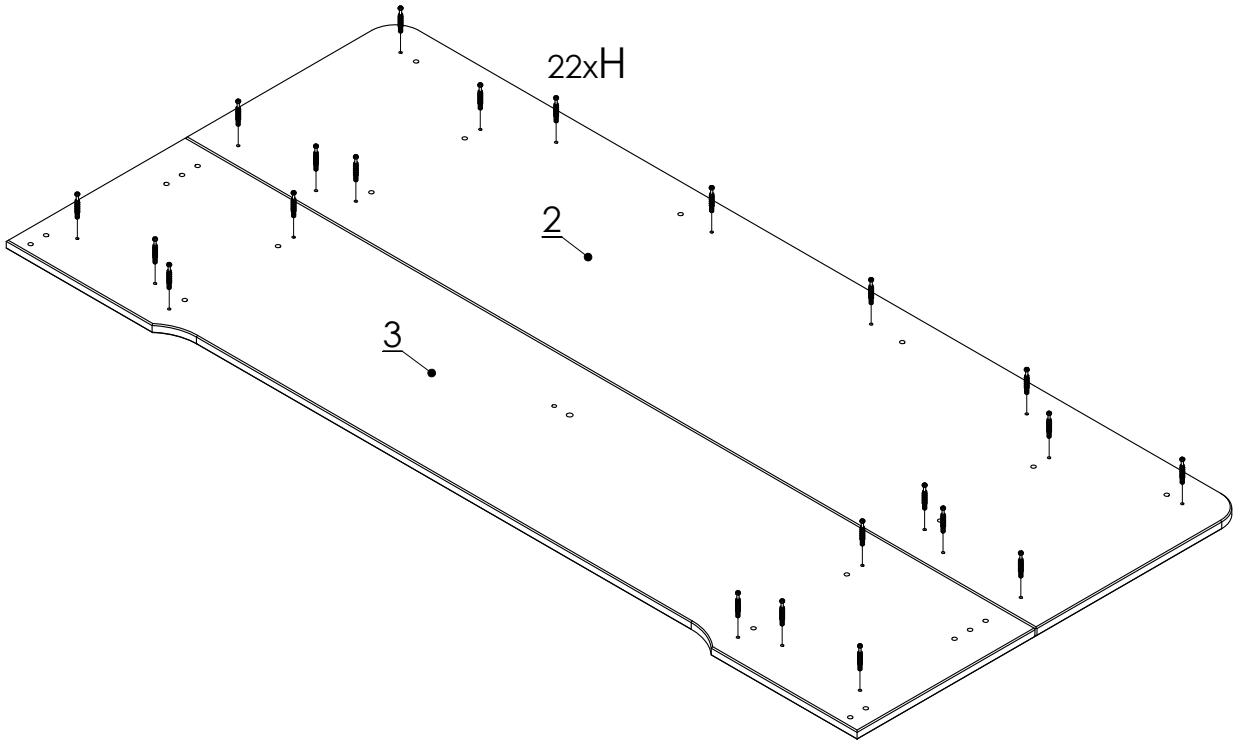
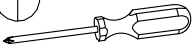

H		7x34	x22
---	--	------	-----

4

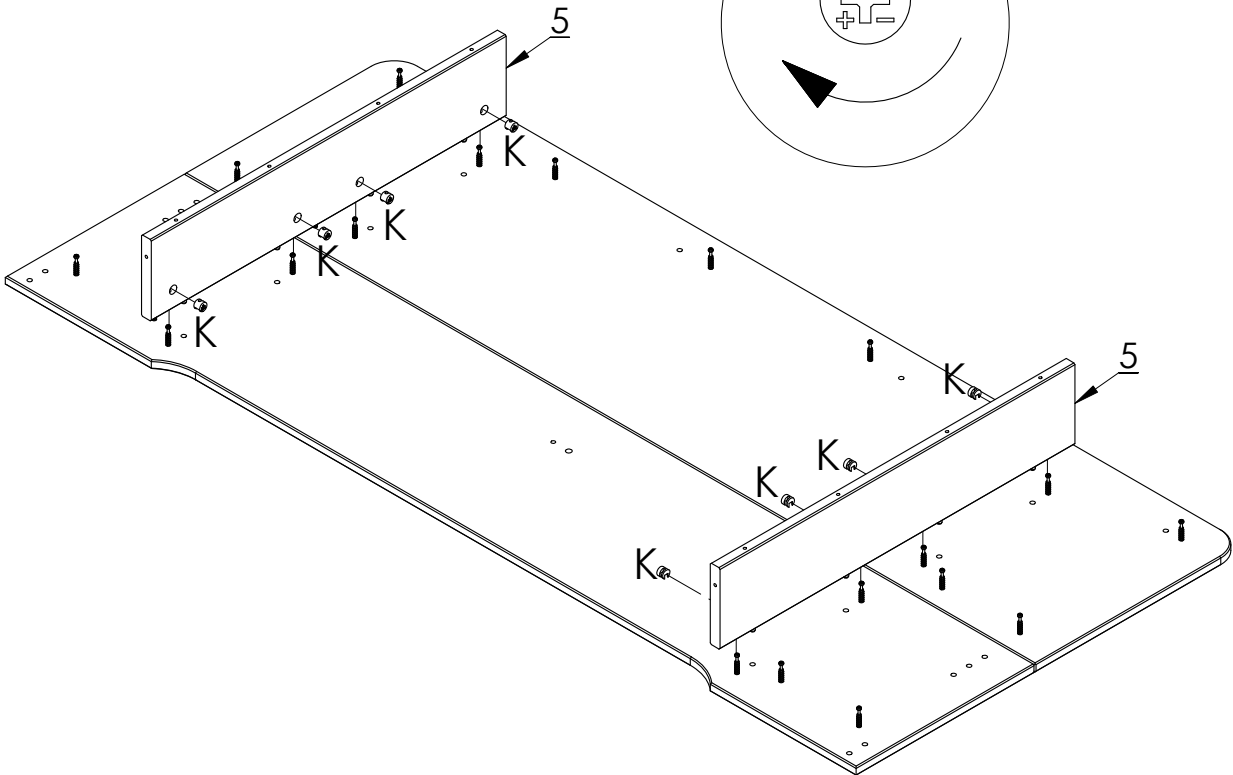
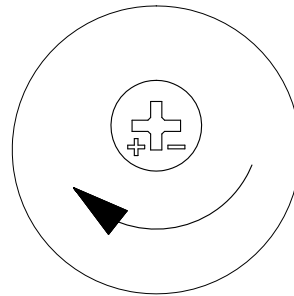
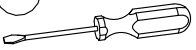

K		15x12	x8
---	--	-------	----

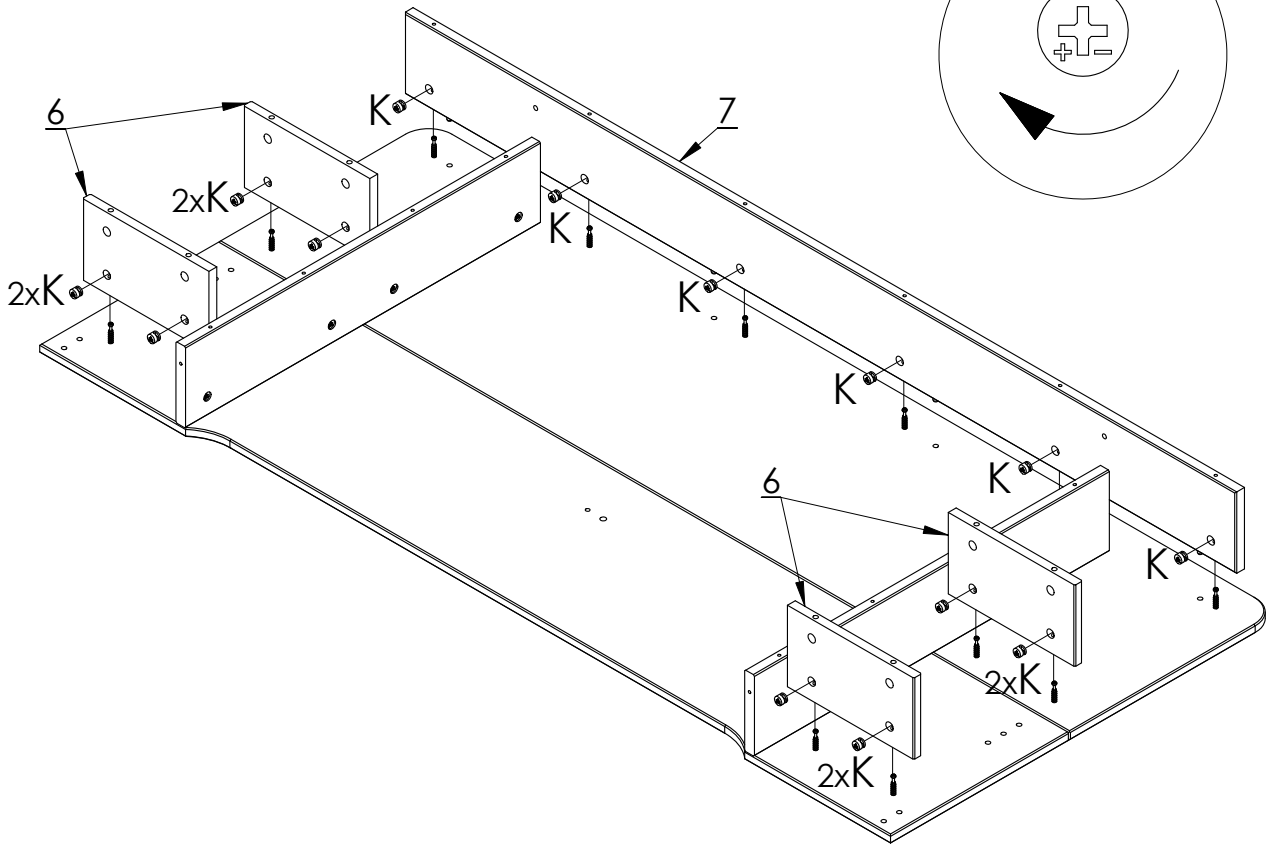
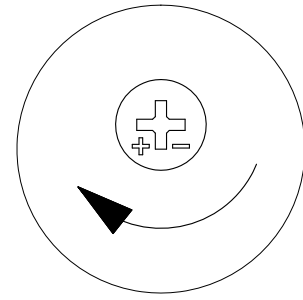
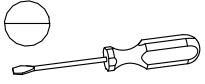

5

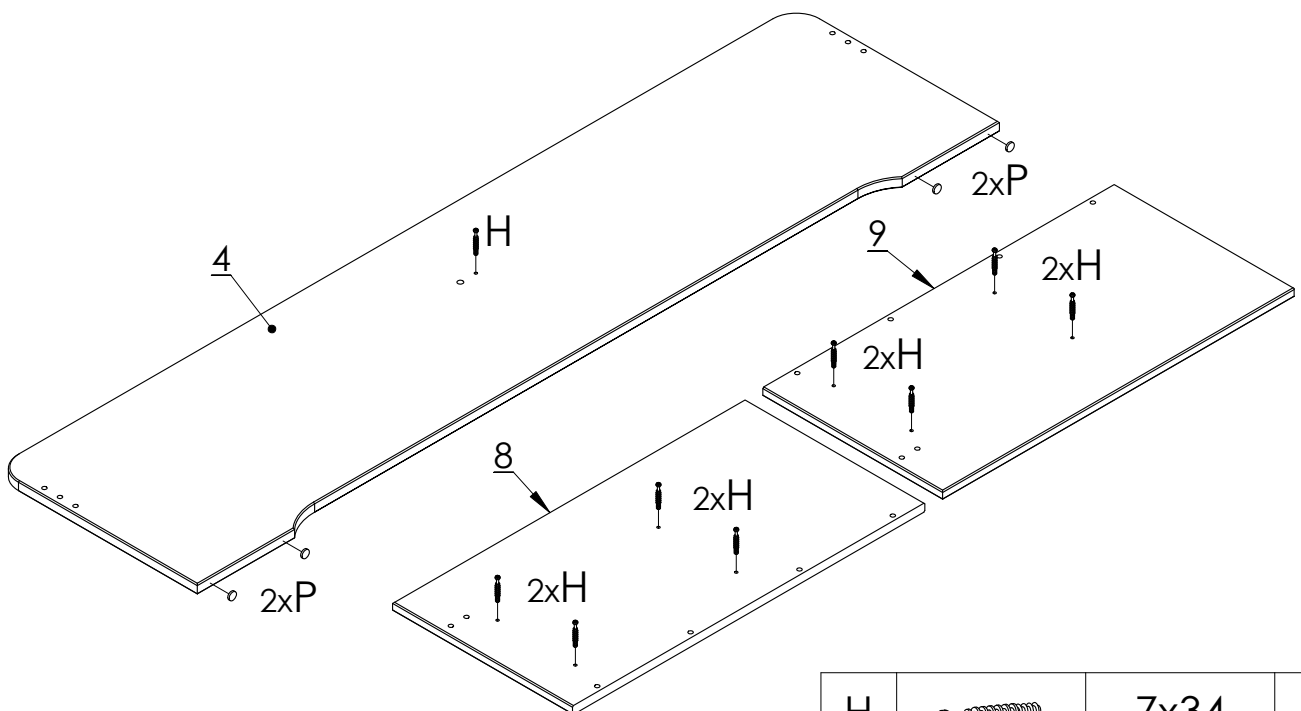
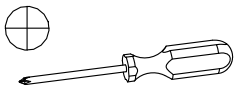

K		15x12	x14
---	---	-------	-----

6



H		7x34	x9
P		D17x3	x4

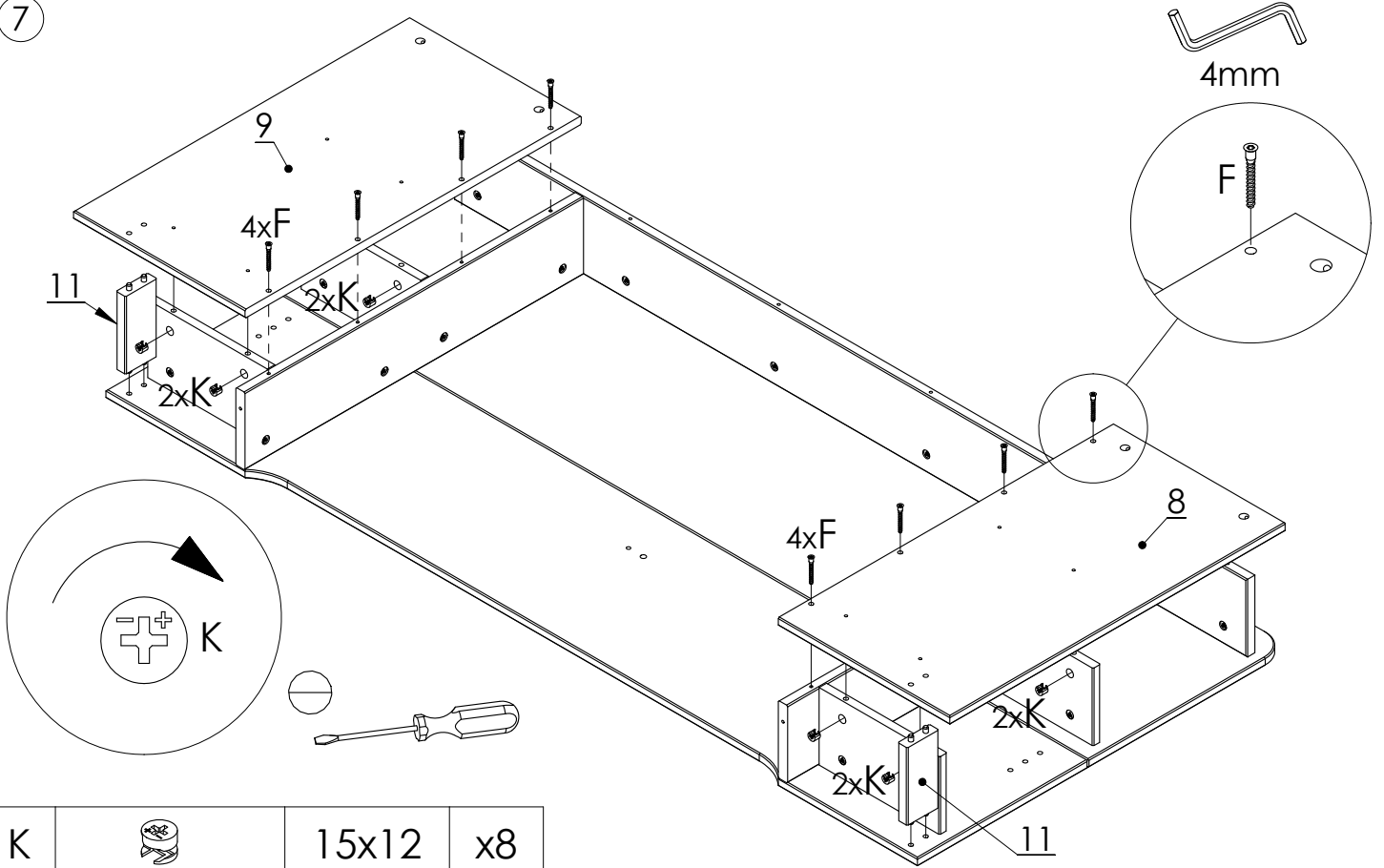

7

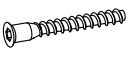

K		15x12	x8
F		7x50	x8

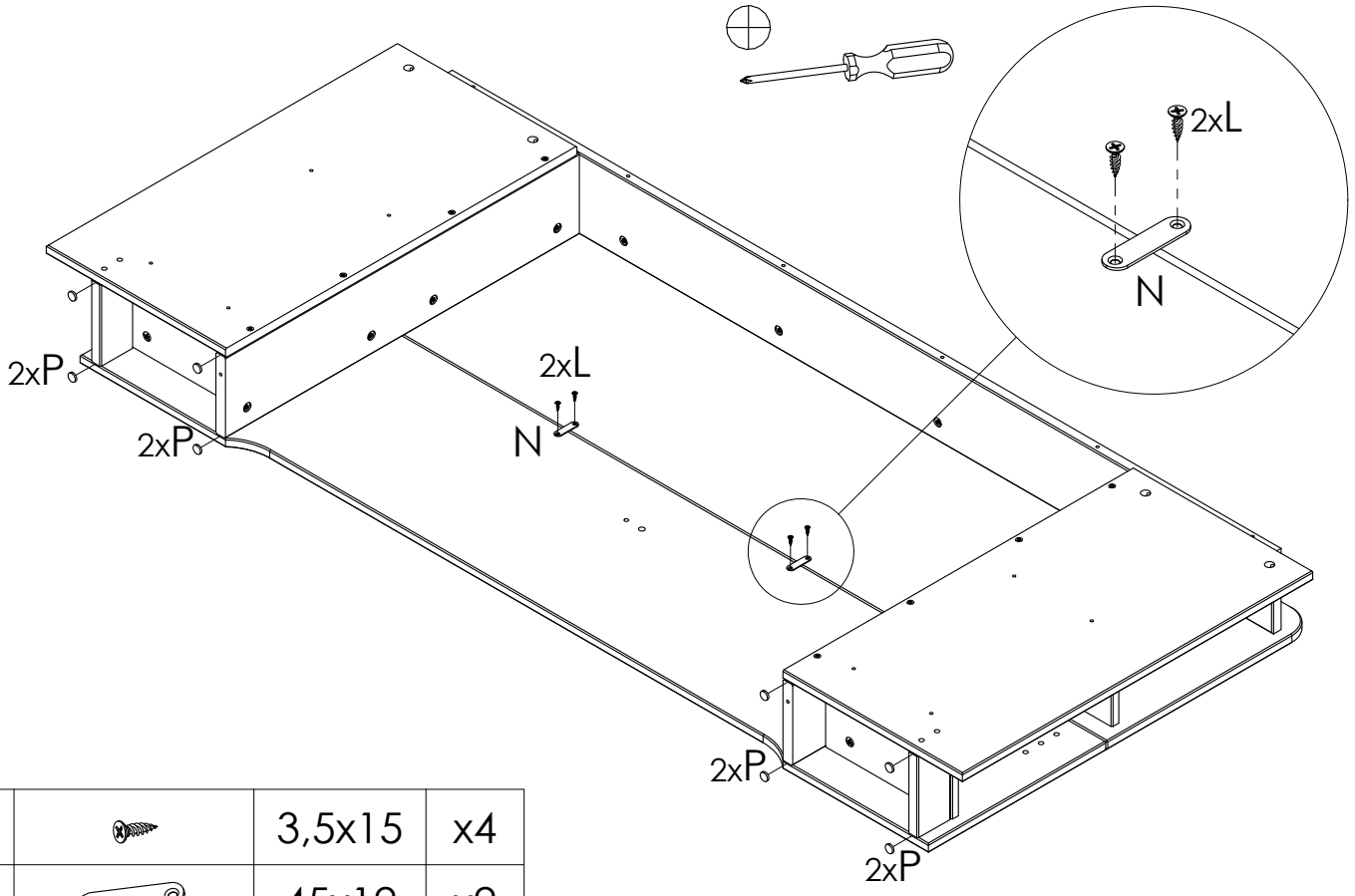

8

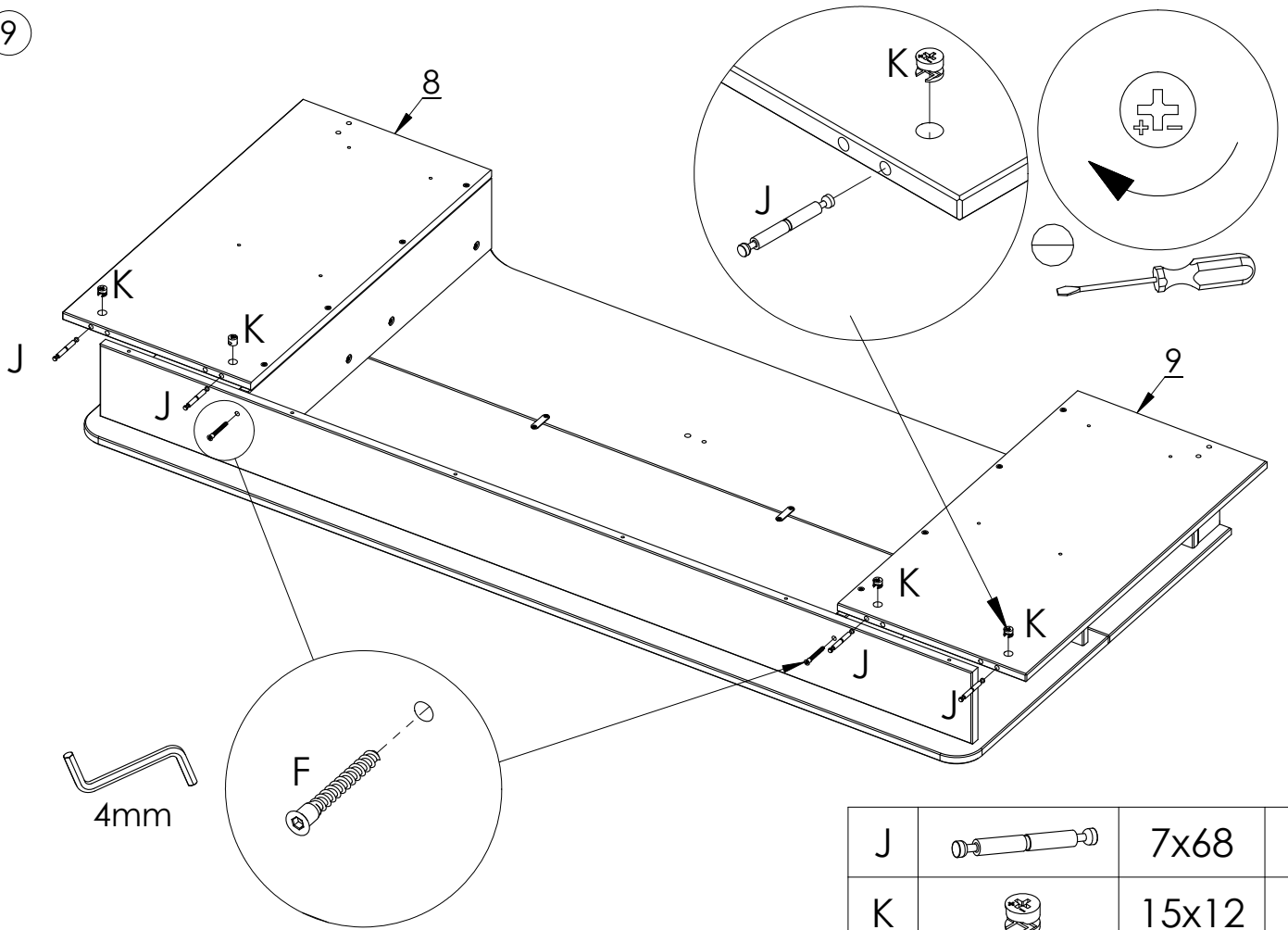

L		3,5x15	x4
N		45x12	x2
P		D17x3	x8

9



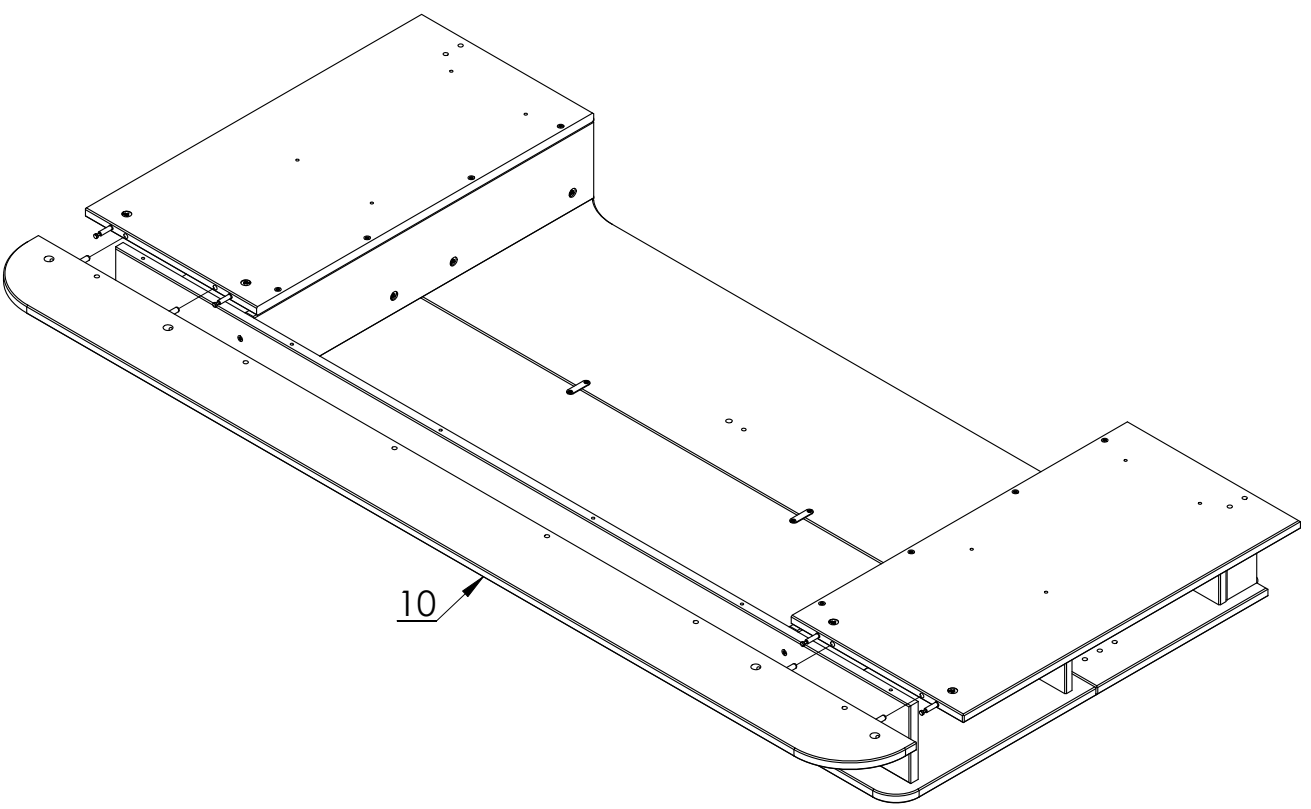

J		7x68	x4
K		15x12	x4
F		7x50	x2

10

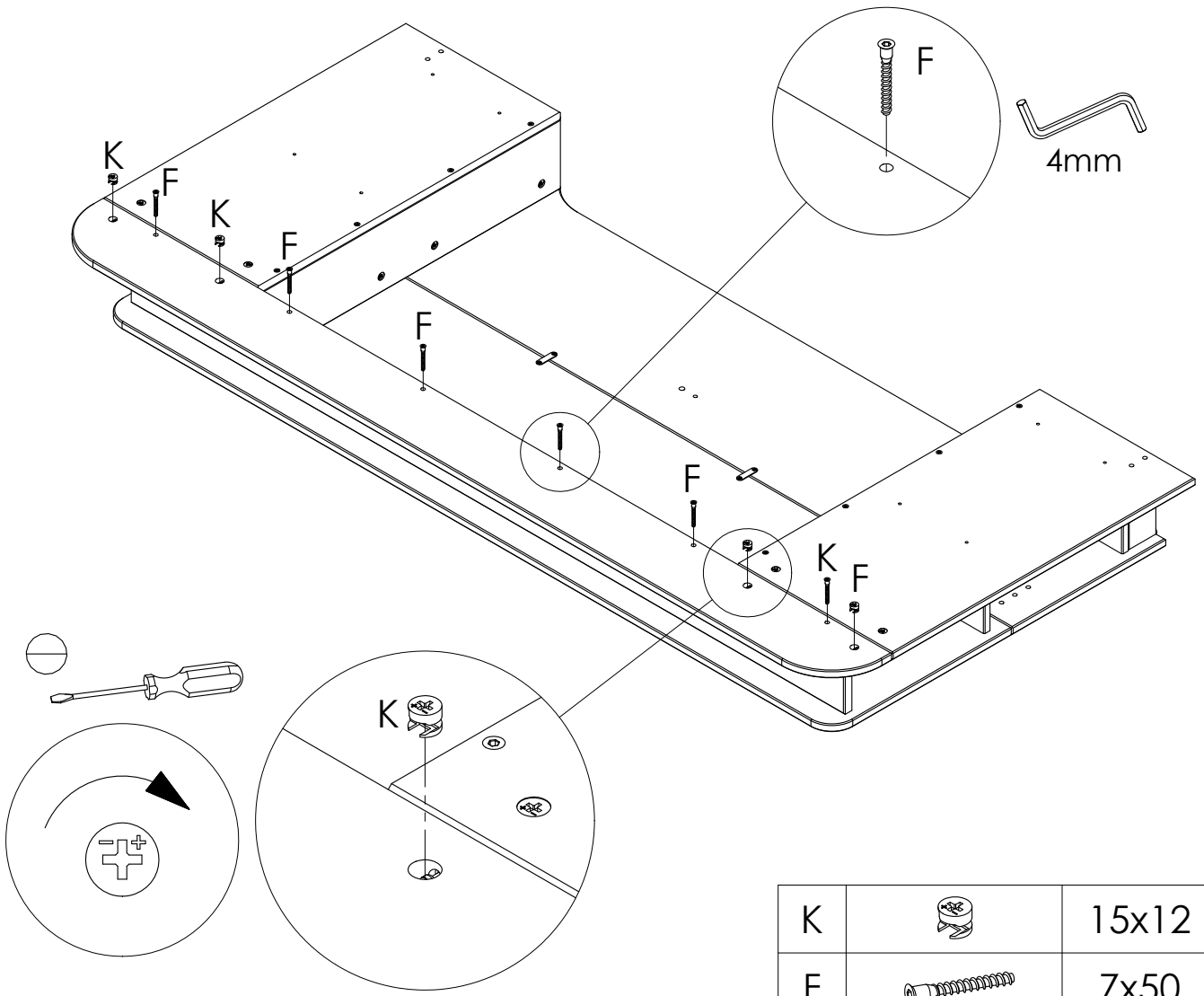

11



K		15x12	x4
F		7x50	x6

12

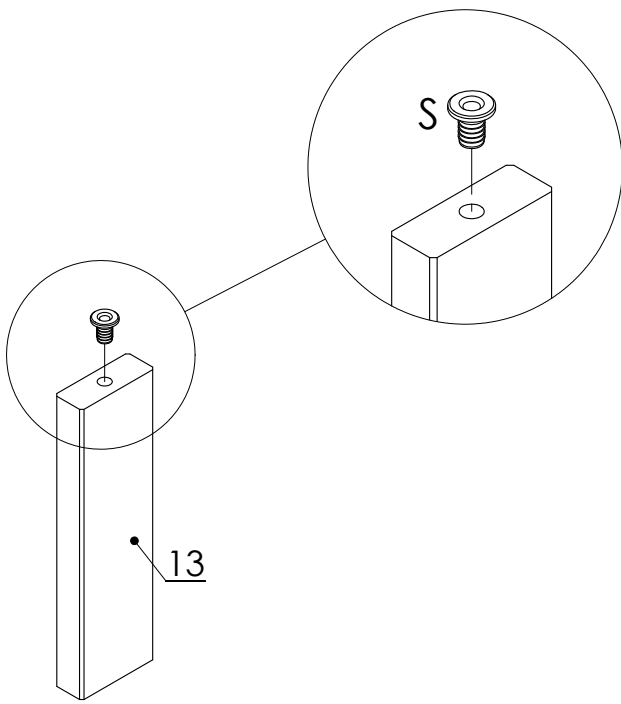

S		M8x20x10,4	x1
---	---	------------	----

13

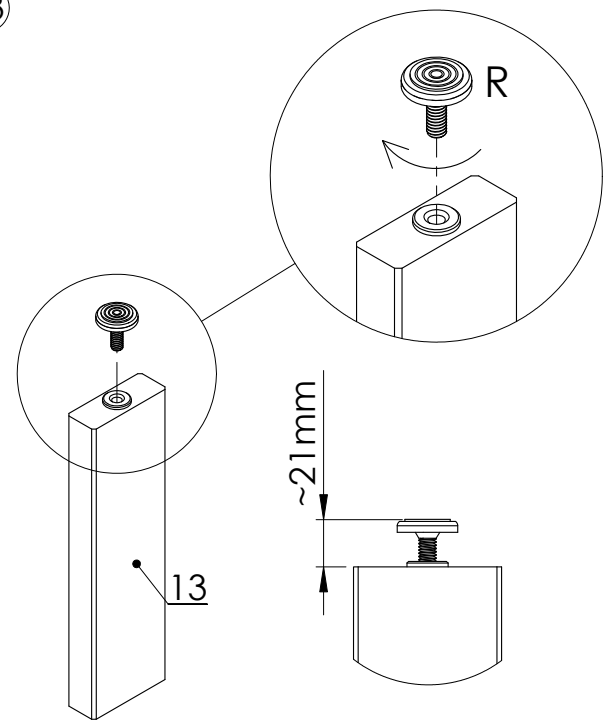

R		M8x20xD28	x1
---	---	-----------	----

14

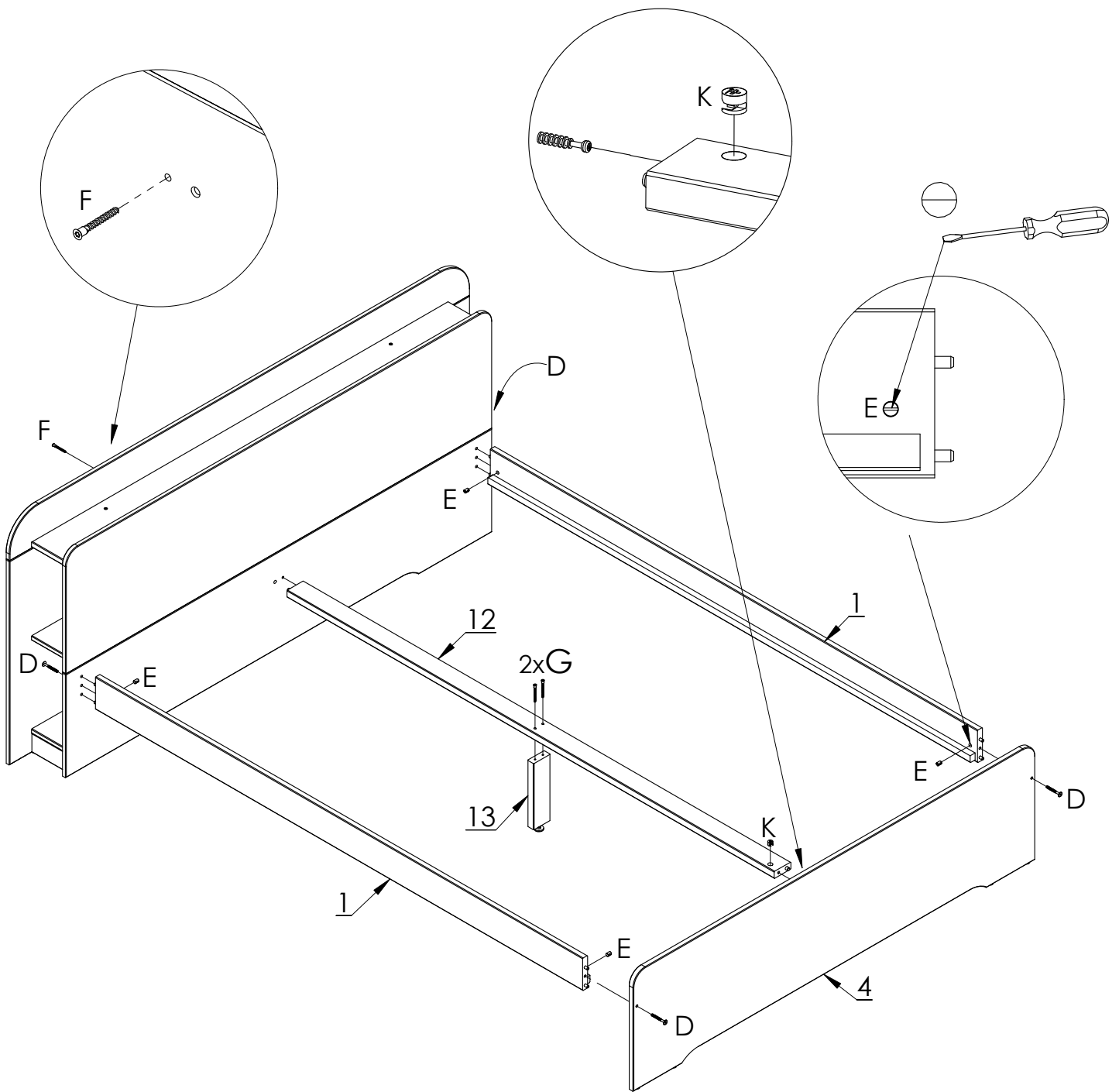
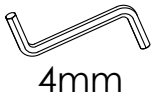

F		7x50	x1
G		7x60	x2
K		15x12	x1

D		M6x55	x4
E		M6x10x13	x4

15

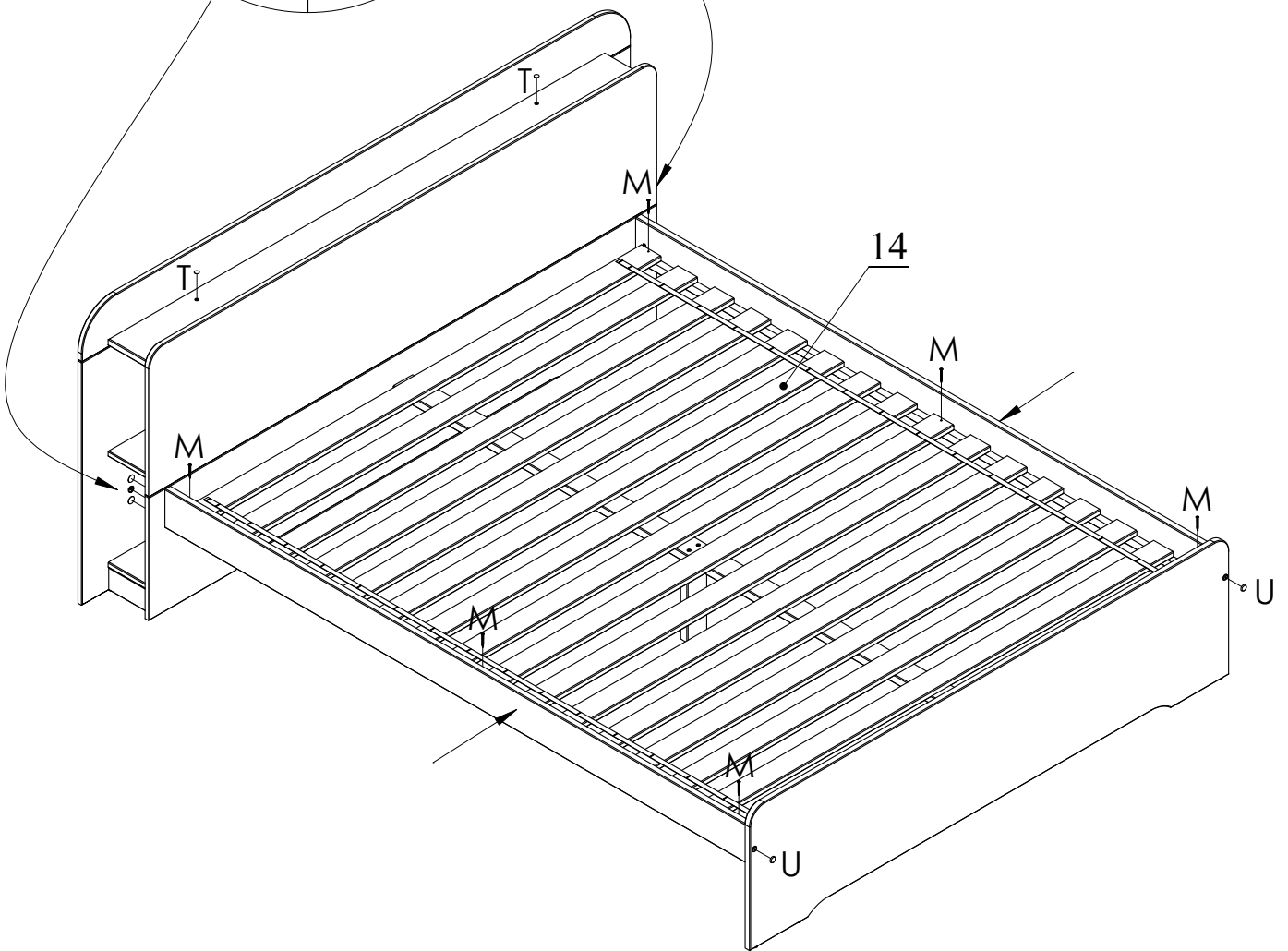
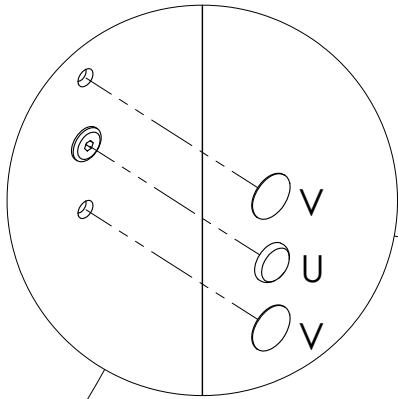
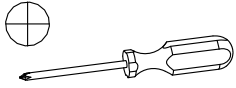

T		D4x13	x2
M		3,5x40	x6

U		D15x18	x4
V		D20	x4

_GEBRUIK EN ONDERHOUD

Elk meubelstuk heeft zijn eigen bijzondere eigenschappen. Ook de staat en structuur van het hout zoals noesten bij natuurhouten meubelen maken deel uit van de individuele look en feel van elk afzonderlijk meubelstuk. Omdat meubelen van natuurhout zijn blootgesteld aan permanente klimaat- en vochtigheidsschommelingen, kunnen er af en toe wijzigingen optreden van de bovenlaag in de vorm van haarscheurtjes of kleurveranderingen. Over het algemeen neemt na verloop van tijd de helderheid af en de kleurverzadiging toe – het hout wordt donkerder. Deze veranderingen zijn gevolgen van een natuurlijk proces wat plaatsvindt bij materialen zoals hout. Deze instructie geeft u een aantal tips over het onderhoud van uw meubelstuk, zodat u er lange tijd plezier aan kunt beleven.

In principe geldt

- Plaats geen hete voorwerpen op de meubelen.
- Plaats geen kaarsen direct op de meubelen.
- Veeg gemorste vloeistoffen direct weg.
- Controleer regelmatig de stevigheid en houvast van schroeven en bevestigingspunten.
- De typische houtgeur is een kwaliteitsbewijs bij natuurhouten meubelen.
- Heldere plekken bij noesten ontstaan door een natuurlijk uittreden van hars en kunnen worden weggepolijst met een droge, pluisjesvrije doek.
- Ook van andere houten, gelakte, lederen of gestoffeerde materialen is een lichte eigen geur bij nieuwe artikelen niet te vermijden. Deze geuren verdwijnen na enige tijd vanzelf. U kunt dit proces versnellen door regelmatig uw huis te ventileren en/of de meubelen af te vegen met water en een kleine hoeveelheid azijn.
- Bewaar deze instructie goed.

Onderhoudsinstructies voor geloogde/ geoliede meubelen van natuurhout

De bovenlaag van uw nieuwe meubelstuk is behandeld met natuurlijke olie. Om deze natuurlijke glans te bewaren, raden we u aan het meubel af en toe verder te behandelen met een geschikte meubelolie, zie wehkamp.nl voor meer informatie. Omdat door de soort oppervlaktebehandeling eventuele resten van natuurolie kunnen achterblijven, raden we u aan de meubelen af te wrijven met een pluisvrije doek.

Onderhoudsinstructies voor natuurlijke/gelakte meubelen van natuurhout

De bovenlaag kan het best met een vochtige doek worden gereinigd.

Opgelet: Bijtende of oplosmiddelhoudende reinigingsmiddelen of polijstmiddelen mogen niet worden gebruikt.

Onderhoudsinstructies voor meubelen van plaatmateriaal

Gebruik voor de reiniging van uw meubel een zachte, niet pluizige doek of een zeemleren doek. Veeg met een vochtige doek de oppervlakten af.

Wij adviseren u de volgende artikelen **niet** te gebruiken:

- **Microvezeldoeken.**
Deze bevatten vaak fijne slijpdeeltjes die kunnen leiden tot krassen op de oppervlakken.
- **Chemische substanties zoals schurende poets- of oplosmiddelen.**
Deze kunnen de oppervlakken eveneens beschadigen.
- **Schuurpoeder, staalwol of pannensponzen.**
Ze vernielen het oppervlak zo erg dat een reparatie niet meer mogelijk is.
- **Stofzuiger.** Mondstukken en borstels kunnen krassen op de oppervlakken veroorzaken.
- **Stoomreiniger.** Door de hoge druk en de hitte, waarmee de stoom op de bovenlagen komt, kunnen deze worden beschadigd of zelfs loskomen van de ondergrond.

NOUS

LIVING

_USE AND MAINTENANCE

No matter if you bought a piece of furniture made from natural wood, a high-gloss front or a plastic front – every piece of furniture has unique characteristics. Even the texture and structure of wood, such as small knots in natural wood furniture, are part of the individual charisma of each piece of furniture. Since natural wood furniture are permanently exposed to climate and humidity fluctuations, changes to the surface may occur (e.g. hair cracks or changes in colour) in some cases. In general, brightness decreases and colour saturation increases in the course of time the wood darkens. The changes mentioned above are normal for natural raw materials such as wood. This booklet provides some care tips for your piece of furniture so that you can enjoy it for a long time.

In general we advise you not to use the following

- Don't place any hot objects on the furniture.
- Don't place candles directly on the furniture.
- Immediately wipe off any spilled liquids.
- Regularly check if the screws and fittings are tight.
- The typical, aromatic wooden odour is always a proof of quality for natural wood furniture.
- The natural emission of resin may produce bright spots on the knots which can be polished with a dry, lintfree cloth.
- Initially, a slight intrinsic odour is unavoidable for other wooden, paint, leather or upholstery materials too.
- These odours automatically disappear after a while. If you want to speed up this process, ventilate more often at the beginning and/or wipe out the furniture with a slightly damp cloth which was soaked in water mixed with a small amount of vinegar.
- Keep these notes in a safe place.

Care notes for stripped/oiled furniture made of natural wood

The surface of your new piece of furniture has been treated with pure organic oil. We recommend an occasional after treatment with suitable furniture oil to preserve this natural, stripped/oil gloss. Since some residue of natural oil may remain on the furniture due to the surface treatment method, we recommend to rub off the furniture with a lint-free cloth, visit wehkamp.nl for more information. After use, let the cloth dry completely before disposal.

Care notes for untreated/painted furniture made of natural wood

Using a moderately damp cloth is the most suitable method for cleaning the surface.

Attention: Corrosive cleaners as well as cleaners containing solvents or polish must not be used.

Care notes for furniture made of panel materials

We recommend using a soft, lint-free cloth or a shammy for conditioning your piece of furniture made of panel materials. Wipe off the surfaces with a slightly damp cloth of shammy.

The following applies in general

- **microfibre cloths** or **dirt erasers.** They often contain fine abrasive particles which can cause scratches on the surfaces;
- **aggressive chemical substances** as well as **abrasive cleaning agents** or **solvents.** They may damage the surfaces too;
- **scouring powder, steel wool** or **scouring pads.** They destroy the surface so badly that reconditioning is impossible;
- **vacuum cleaners.** The nozzles and brushes can cause scratches on the surfaces;
- **steam cleaners.** The surfaces may be damaged or separated from the ground due to the high pressure and heat of the water vapour.